



CREATING **GREEN BUFFERS**

IN THE
GREENPOINT
INDUSTRIAL AREA

**NYS ATTORNEY GENERAL'S
OFFICE**

**NEW YORK CITY SOIL AND
WATER CONSERVATION
DISTRICT**

FUNDED BY:

**NYS DEPT OF
ENVIRONMENTAL
CONSERVATION**

**NATIONAL FISH AND
WILDLIFE FOUNDATION**

PREPARED BY:

EVERGREEN EXCHANGE

eDESIGN DYNAMICS

BROOKLYN, NY

MARCH 2018



APPENDICES

1. MAP OF POLLUTION PLUME
2. NYC DOT SITING GUIDELINES
3. NYC DPR TREE PLANTING STANDARDS I
4. NYC DPR TREE PLANTING STANDARDS II
5. NYC DOT REVOCABLE CONSENT RULES
6. NYS RAINWATER HARVESTING GUIDELINES
7. GROW NYC HARVESTING 101
8. PROJECT AREA CSO MAP
9. PROJECT AREA ZONING & LAND USE MAP



APPENDIX

one

MAP OF
POLLUTION PLUME



Legend

-  Project Area
-  Plume Area



NORMAN AVENUE

NORTH HENRY STREET

MONITOR STREET

KINGSLAND AVENUE

SUTTON STREET

NASSAU AVENUE

HAUMAN STREET

MORGAN AVENUE

APOLLO STREET

ALLEY

VAN DAM STREET

MEEKER AVENUE

NEWTOWN CREEK SHORELINE

QN-KINGS CNTY BOUNDARY

VARICK STREET

BRIDGEWATER STREET

THOMAS STREET

BROOKLYN QUEENS EXPWY ET 34 WB

BROOKLYN QUEENS EXPRESSWAY

BQE EB ENTRANCE VANDERVOORT AVE

CHERRY STREET

VARICK AVENUE



APPENDIX

two

NYC DOT
SITING GUIDELINES

Right-of-Way Bioswale Siting Guidelines



Commissioner Janette Sadik-Khan New York City Department of Transportation

These guidelines are not intended as criteria but minimum standards and first steps in the siting process. Every location which meets these standards will be reviewed individually by DOT.



ROWB Site Selection Guidelines

ROWBs shall preferably be located in low to moderate density areas



ROWB Site Selection Guidelines

ROWBs proposed for areas of high pedestrian volume must be reviewed by DOT.



ROWB Site Selection Guidelines

8' (R6-R10, Commercial)
5' (R1-R5)

ROWBs should maintain a minimum **8'** clear path in moderate density residential (R6-R10), manufacturing, and all commercial areas while a **5'** clear path must be maintained in low density residential settings (R1-R5)*.

*Refer to New York City Department of City Planning Zoning Districts

For locations where this requirement can't be met, DOT will evaluate on a case-by-case basis**. The 8' or 5' clear path is offset from the lot-line of the property; this may or may not be the same as the building line

**ROWBs exceeding standard lengths and widths must be reviewed by DOT for approval. All minimum requirements should still be maintained.

ROWB Site Selection Guidelines

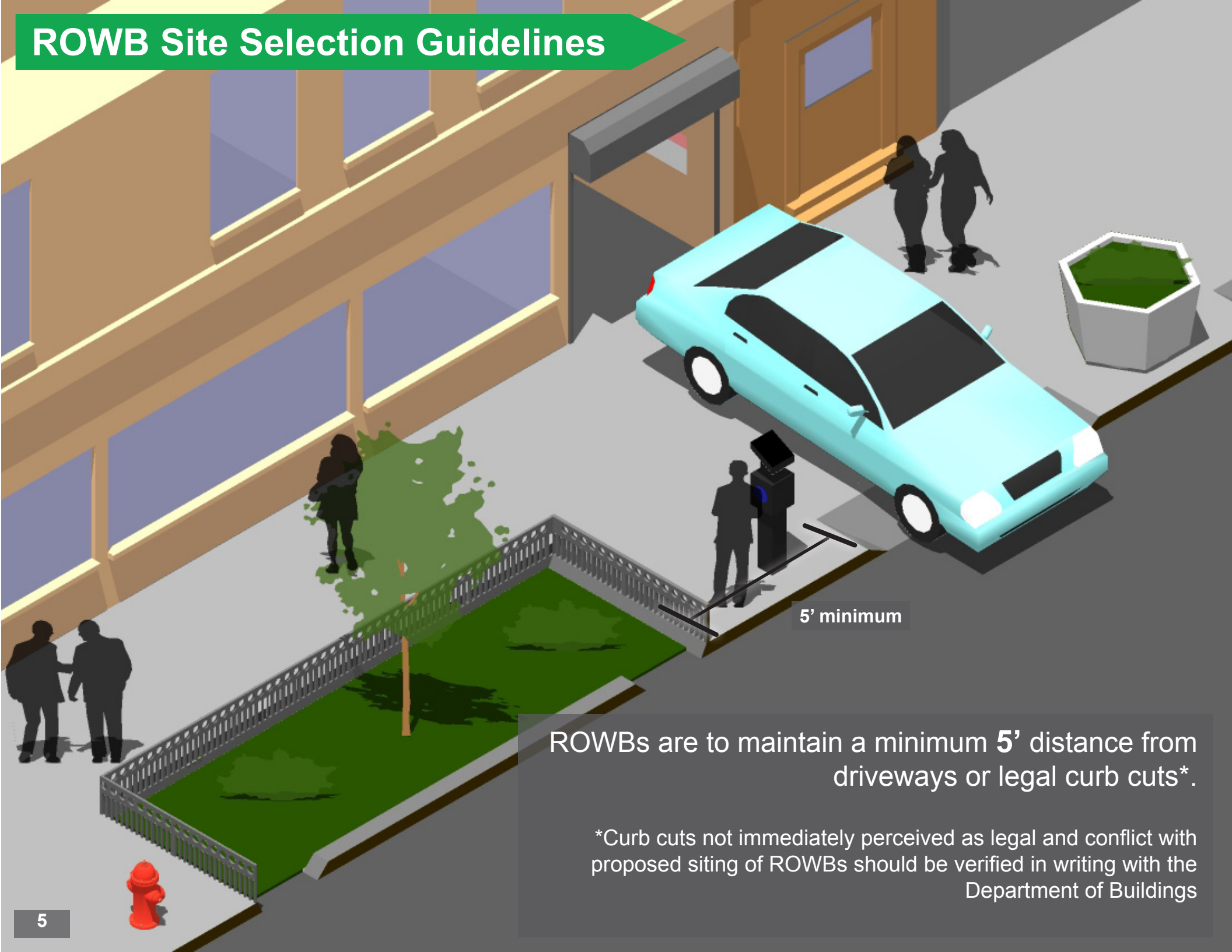

5' minimum

ROWBs are to maintain a minimum **5'** distance from driveways or legal curb cuts*.

*Curb cuts not immediately perceived as legal and conflict with proposed siting of ROWBs should be verified in writing with the Department of Buildings

ROWB Site Selection Guidelines

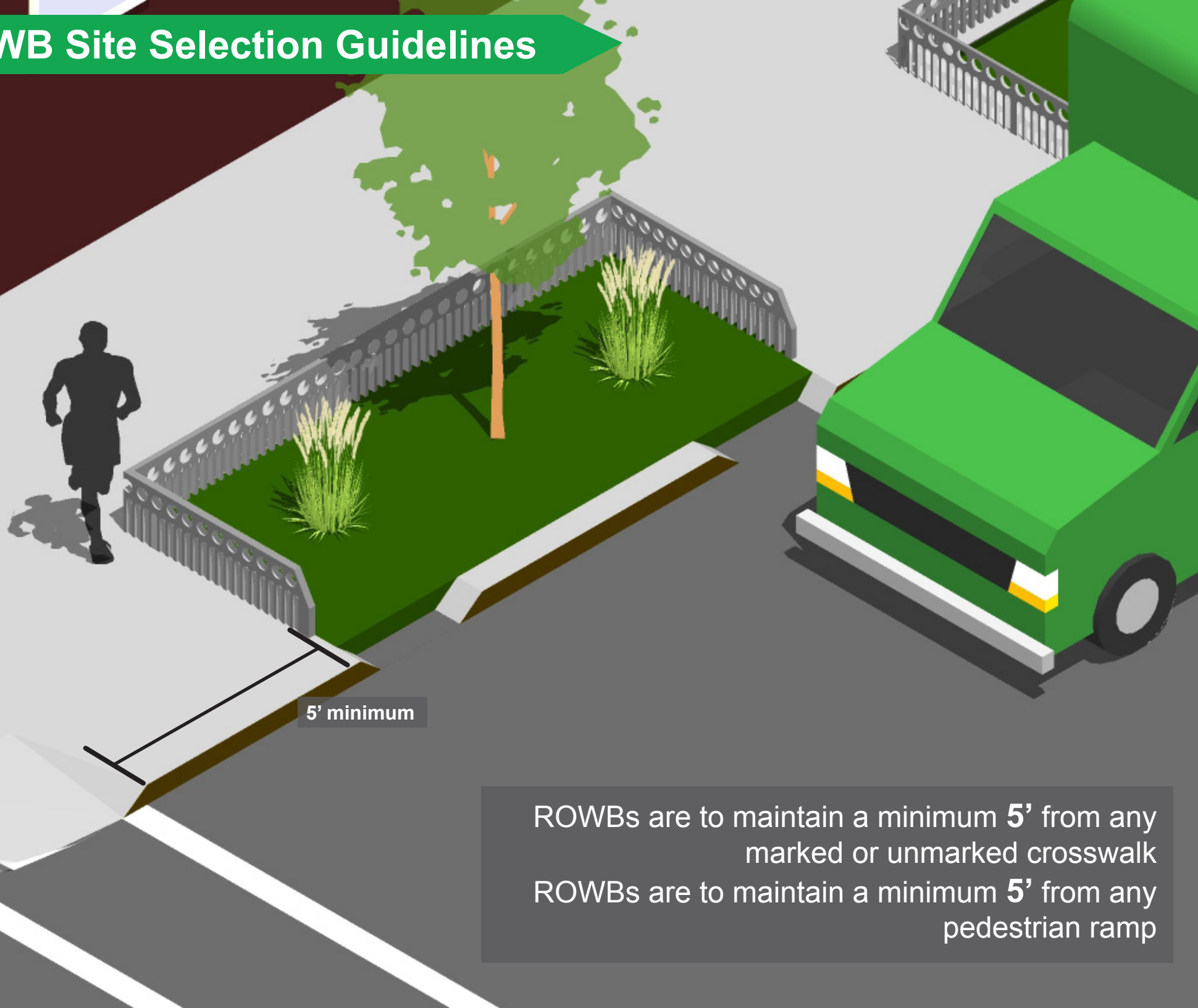

5' minimum

ROWBs are to maintain a minimum **5'** from any marked or unmarked crosswalk
ROWBs are to maintain a minimum **5'** from any pedestrian ramp

ROWB Site Selection Guidelines

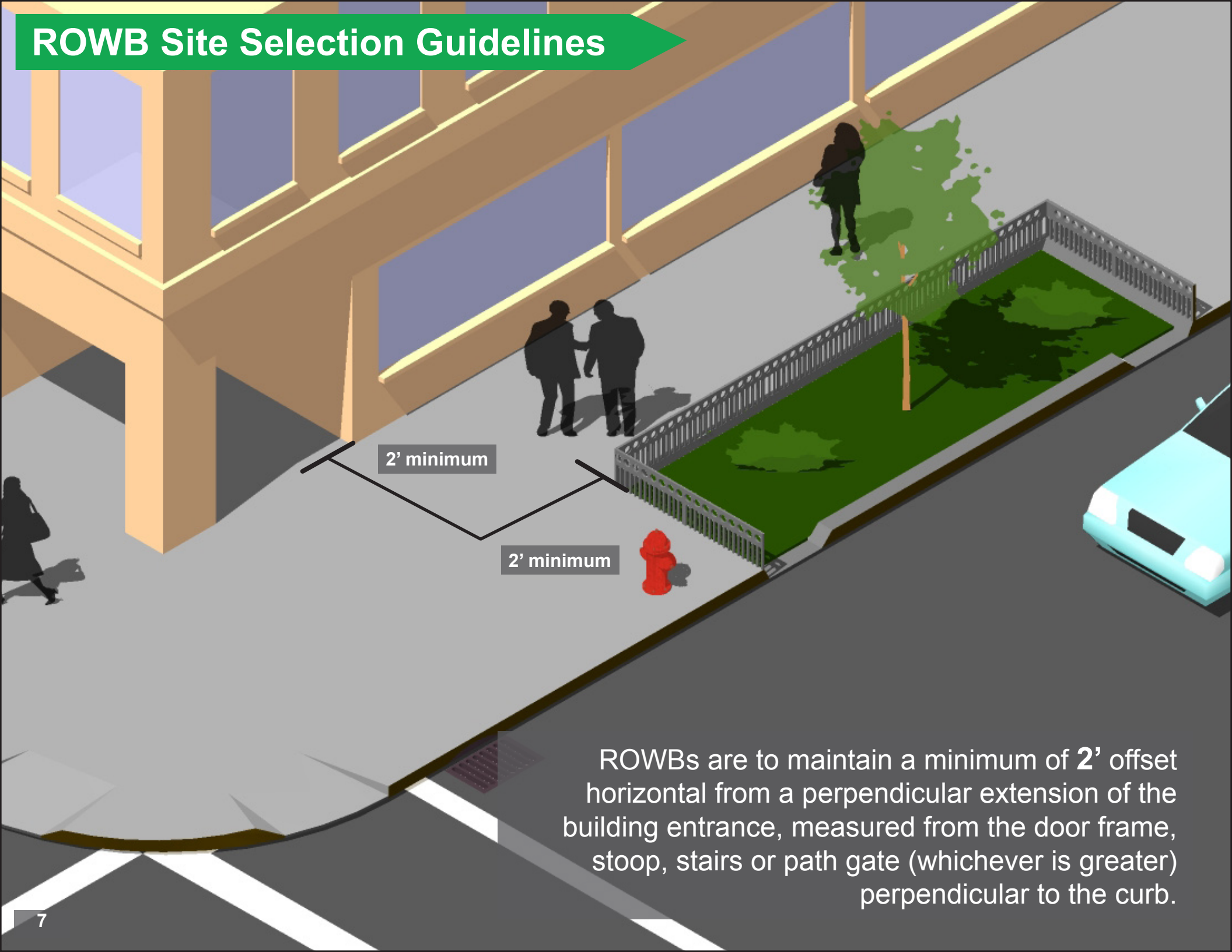

2' minimum

2' minimum

ROWBs are to maintain a minimum of **2'** offset horizontal from a perpendicular extension of the building entrance, measured from the door frame, stoop, stairs or path gate (whichever is greater) perpendicular to the curb.

ROWB Site Selection Guidelines

ROWBs shall not violate any building code requirements



ROWB Site Selection Guidelines

Sidewalk corners must be kept clear.



ROWB Site Selection Guidelines

3' or greater

1' additional

ROWBs are to maintain an additional 1' of sidewalk clearance when sited adjacent to walls or fences 3' or greater in height. In locations where the additional 1' clearance cannot be met, Type III (10' long) ROWBs may be permitted.

ROWB Site Selection Guidelines

ROWBs must not be sited within 100' of either side of a posted bus stop.



ROWB Site Selection Guidelines

ROWBs must not be sited within a **10'** radius of subway entrances and exits. ROWBs sited within the vicinity of underground subway structures, sites are to be coordinated with NYCTA.



ROWB Site Selection Guidelines

ROWBs are to maintain a minimum 5' from any revocable consent structure.

5' minimum



ROWB Site Selection Guidelines

ROWBs are to maintain a minimum 5' from building vaults.

5' minimum



ROWB Site Selection Guidelines



ROWB tree guards must not exceed **18-24"** in height.
ROWB tree guards should be no closer than **18"** to face of curb.

ROWB Site Selection Guidelines

3' each side

4' each side

ROWBs are to maintain a minimum 3' clear path between either side of adjacent fire hydrants.
ROWBs are to maintain a minimum 4' clear path between either side of adjacent Muni Meters.

ROWB Site Selection Guidelines

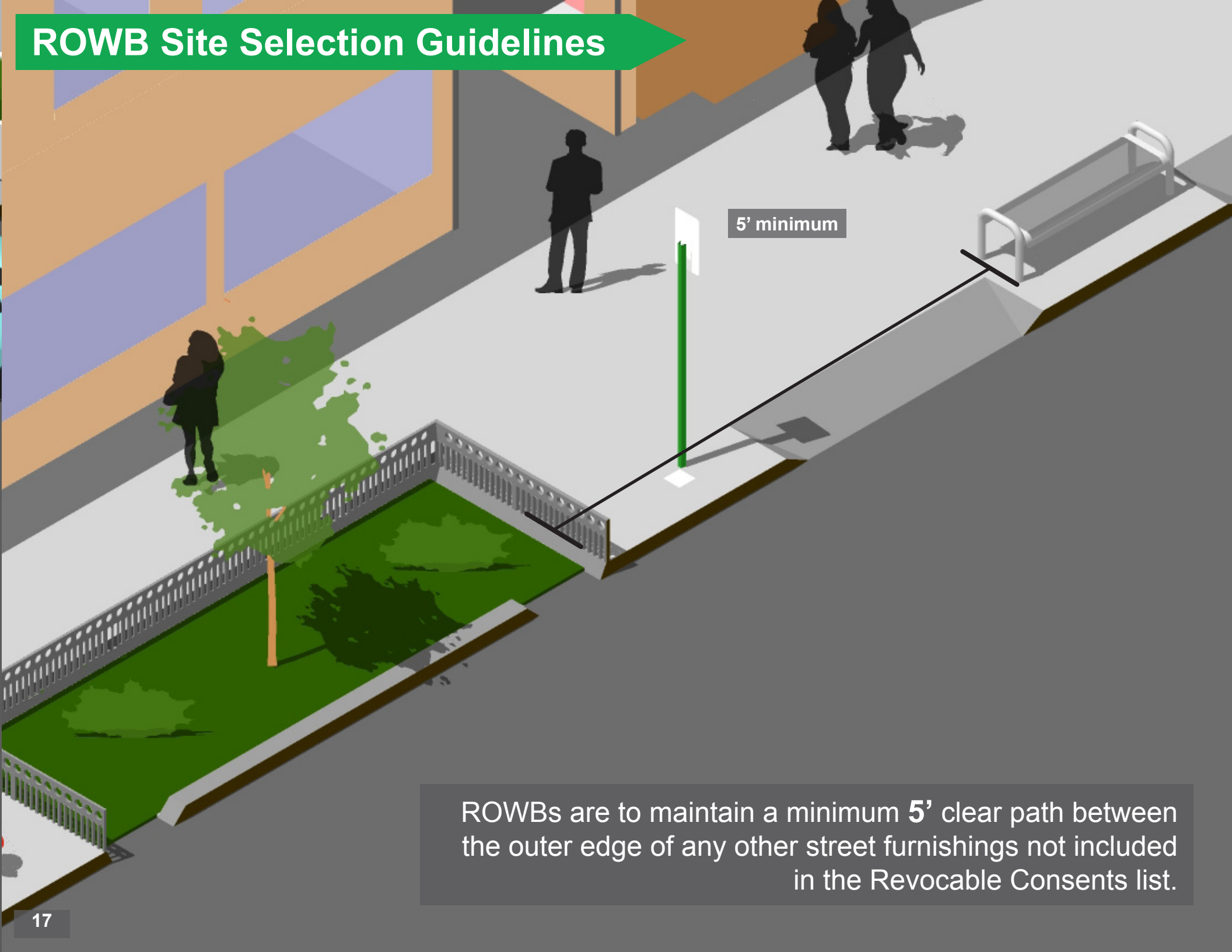

5' minimum

ROWBs are to maintain a minimum **5'** clear path between the outer edge of any other street furnishings not included in the Revocable Consents list.

ROWB Site Selection Guidelines

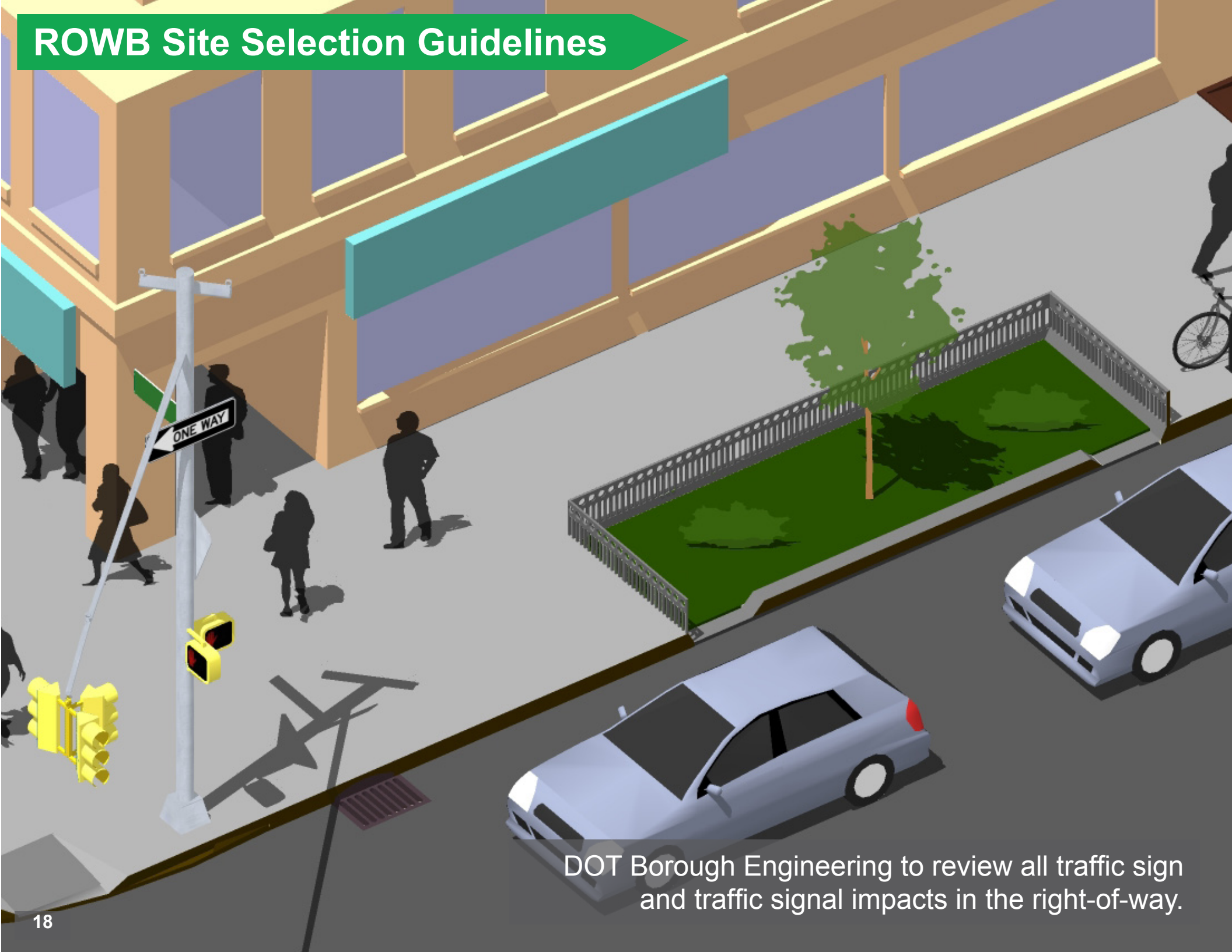

DOT Borough Engineering to review all traffic sign and traffic signal impacts in the right-of-way.

ROWB Site Selection Guidelines

Relocation of street furniture such as bike racks and benches must be coordinated with DOT.



ROWB Site Selection Guidelines



The distance of the trees to the apex of the intersection must be a function of street geometry. Sight line area must meet AASHTO Geometric Design of Highways and Streets sight triangle minimums.

ROWB Site Selection Guidelines

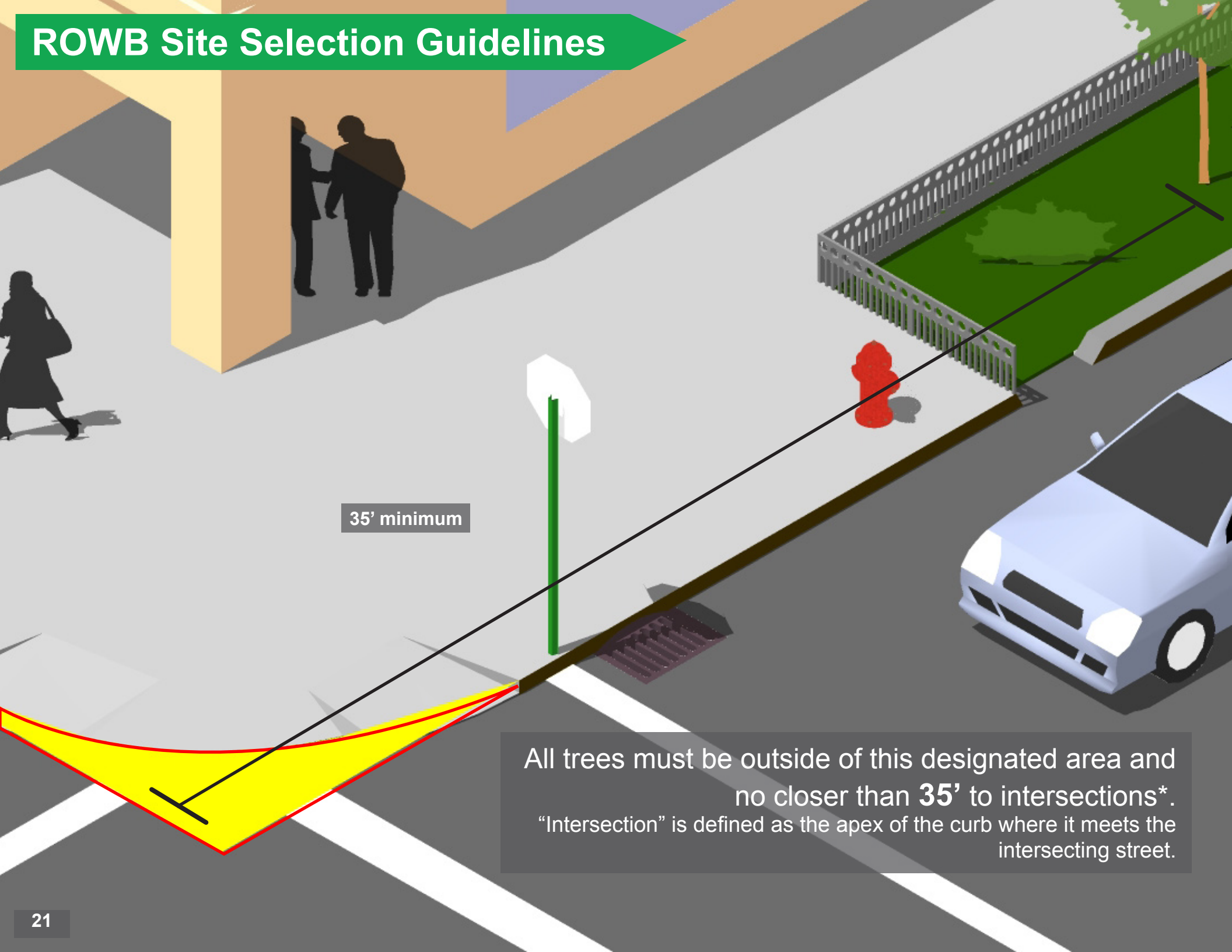

35' minimum

All trees must be outside of this designated area and no closer than **35'** to intersections*. "Intersection" is defined as the apex of the curb where it meets the intersecting street.

ROWB Site Selection Guidelines

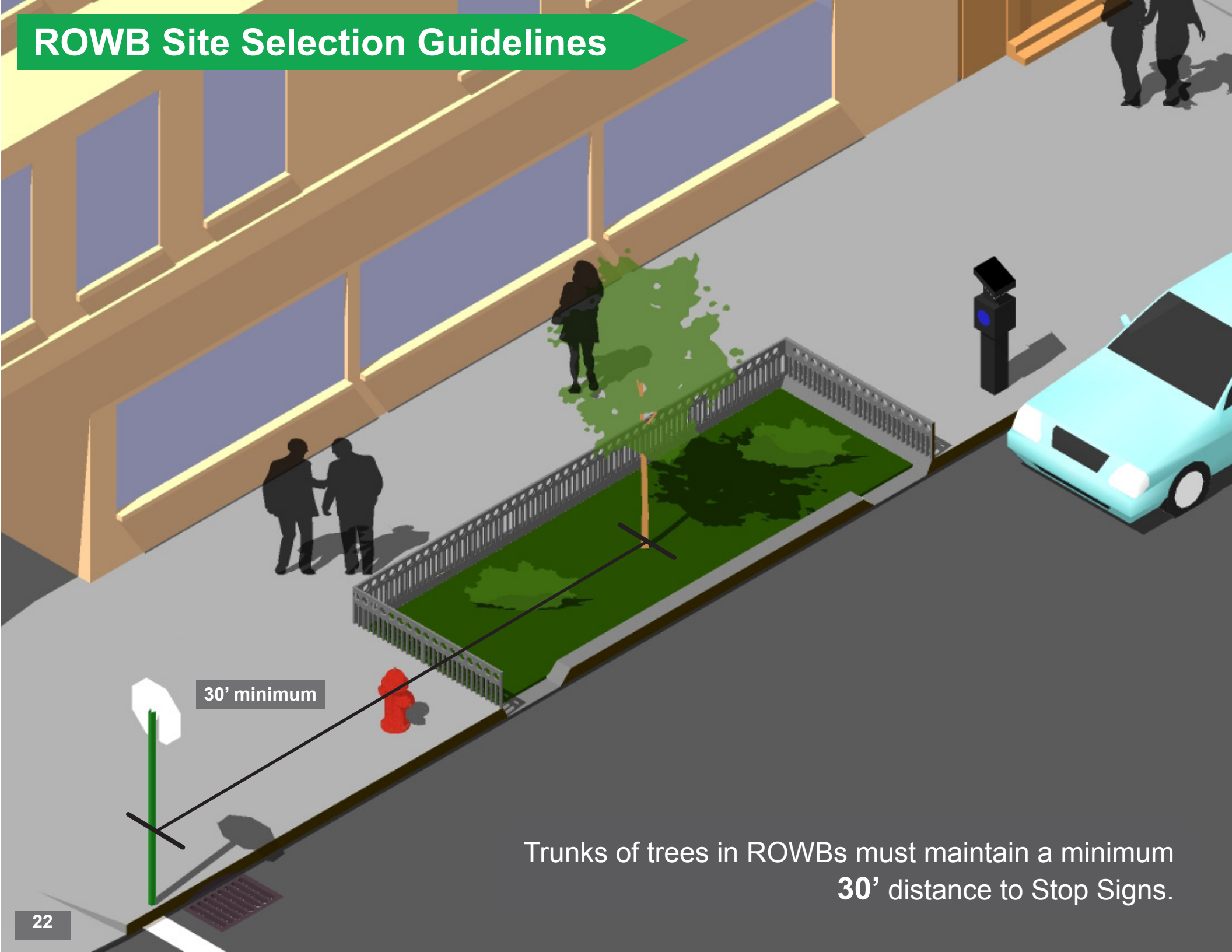

30' minimum

Trunks of trees in ROWBs must maintain a minimum **30'** distance to Stop Signs.

ROWB Site Selection Guidelines

Trunks of trees in ROWBs must maintain a minimum **25'** distance to street lights and traffic signals per DPR Tree Planting guidelines. A minimum of **5'** clearance between pit edge of ROWB and street light footing must be maintained.

Trunks of trees in ROWBs must maintain a minimum **10'** distance to utility poles. A minimum of **5'** clearance between pit edge of ROWB and utility pole must be maintained.

DPR discretion may be used when siting trees closer than 25' to a light pole.



25' minimum street lights & traffic signals
10' minimum utility poles

ROWB Site Selection Guidelines



2'6'' maximum

Height of shrubs must not exceed 2'6''.

ROWB Site Selection Guidelines

A minimum **25'** distance must be maintained between the trunk centerline of ROWB trees and the trunk centerline of any existing trees. A minimum **5'** distance is required between the edge of a ROWB and an existing tree pit or bioswale.

*DPR discretion may be used when siting trees closer than 25'.

25' minimum trunk centerlines

5' minimum pit edge

ROWB Site Selection Guidelines



All trees in bioswales must adhere to DPR's tree planting guidelines as well as the ROWB siting guidelines.

ROWB Site Selection Guidelines



Prior to DOT field review contractor must inform DOT if any ROWBs are proposed within planned or existing historic or landmarked districts.



APPENDIX three

NYC DPR
TREE PLANTING
STANDARDS I



NYC Parks

Tree Planting Standards



**City of New York
Parks & Recreation**

February 2014

TREE PLANTING STANDARDS

Street trees are important to our quality of life in the city. They are living elements of our street infrastructure. Located in the public right-of-way, they provide cooling shade, cleaner air, and more beautiful urban streetscapes. Trees confer important esthetic and ecological benefits to City residents as well. Yet plants in the urban landscape face a variety of environmental and physical stresses, including pedestrian and vehicular traffic, soil compaction, air pollution, and drought. Some of the key factors to maximize long-term plant survival are proper handling, careful planting, and immediate and continued aftercare.

All approved tree planting permit applicants **must** follow these standards. Any tree work improperly performed or otherwise not in accordance with these specifications will be subject to restitution and penalty at the direction of Parks & Recreation and at the expense of the property owner.

1. Design

A. SPACING REQUIREMENTS

The following requirements shall be followed when siting tree pits along sidewalks. These guidelines generally follow regulations of other agencies with right-of-way jurisdictions or infrastructure. These requirements are design and tree species dependent. The Americans with Disabilities Act (ADA) guidelines must be followed.

- a. Do not plant in front of building entrances in order to permit easy access by the Fire Department.
- b. Do not plant within bus stops.
- c. Do not plant directly over DEP water mains less than 20 inches in diameter.
- d. Minimum horizontal distance from DEP water main to tree trunk is 6 feet.
- e. Minimum distance between trees (trunk to trunk) shall be 20' to 30', depending upon the tree species and other local conditions.
- f. Minimum distance from a streetlight to the tree trunk is 25 feet (this may vary with tree species).
- g. Minimum distance from a stop sign to the tree trunk is 30 feet.
- h. Minimum distance from other traffic signs to the tree trunk is 6 feet.
- i. Suggested distance from a parking meter back to tree trunk shall be no more than 5 feet, to allow for the swing of car doors.
- j. Minimum distance from a gas or water valve to the edge of the pit is 2 feet.
- k. Minimum distance from an oil fill pipe to the edge of the pit is 4 feet.
- l. Minimum distance from the edge of a coal chute to the edge of the pit is 2 feet.
- m. Minimum distance from a fire hydrant to the edge of the pit is 3 feet.
- n. Minimum distance from a curb cut or driveway to the edge of the pit is 2 feet and to the tree trunk is 7 feet.

- o. Minimum distance from the corner of a street intersection to the tree trunk is 40 feet.
- p. Minimum distance from the edge of the pit to any opposite obstruction (building wall, stoop, railing, property line etc) is from 4 to 6 feet, depending upon local conditions and the amount of sidewalk traffic.
- q. All tree pits must be contiguous to the street curb (except as noted below, or with the permission of the Agency representative).
- r. Trees may be planted on either side of sidewalks (if any exist) in lawn areas where there is sufficient room between the property line and the street curb.

The locations of all trees shown on plans may be relocated as required by site conditions and as directed by the Agency representative.

B. TREE PIT DIMENSIONS

Tree pits should be as large as possible to allow for ample growing space for tree roots and crown, and to prevent future sidewalk lifting. Optimal tree pit size would be 4 feet by 10 feet or 5 feet by 10 feet. The overall width of a sidewalk can limit the size of a tree pit. Please refer to the Sample Tree Pit Configuration Sheet on page 19 for a range of possible tree pit sizes.

Parks encourages continuous tree pits whenever possible, and designs that call for continuous pits may be given more flexible spacing requirements by the Agency representative.

If the recommended tree pit size does not match the approved site plan, the plan must be revised.

C. GROUPED PLANTINGS

Grouped plantings provide a number of environmental benefits. These benefits include increased shading, reduced evapotranspiration, less soil compaction, greater available soil volume, and reduced exposure to reflective heat for an individual tree. A grouped planting can be achieved in several types of sites: (1) a greenstreet, such as a median or traffic triangle, with opportunity for a large planting bed; (2) a continuous tree pit, where two or more trees are planted in a single trench in the sidewalk (at least 30 feet long); or (3) a raised planting bed as within a plaza or alongside a pedestrian passageway.

D. SPECIES SELECTION

Growing conditions and microclimates can vary from location to location within a borough and across the City. Species selection should take into account site conditions, design goals, and diversity goals. In choosing a tree, the mature height and spread shall be considered to ensure that it will not interfere with existing or proposed structures and overhead utilities. Parks will not allow large to be planted under primary wires. The species characteristics shall be considered to ensure that they will not cause interference with walls, walks, drives, and other paved surfaces, or affect water and sewer lines, underground drainage systems or utilities.

See the attached list of approved street trees for New York City for information on each species shape, growth rate, visual interest, environmental tolerances and sensitivities (including Asian Longhorned beetle hosts), and special needs. Additional species will be considered.

*Final approval of species choice will be made by a New York City Parks & Recreation Representative.

E. CU STRUCTURAL SOIL

Trees are not to be planted directly in CU Structural Soil. CU Structural Soil is only to be used as a base material under impermeable surfaces. Exposed or permeable surfaces should be excavated and replaced with fresh topsoil meeting tree planting specifications. All Structural Soil Installations need approved prior by a New York City Parks forester.

e. Installation:

The Contractor shall notify the Forester of any subsurface conditions which will affect the Contractor's ability to complete the work, and shall locate and confirm the locations of all underground utility lines and structures prior to starting any excavation in the area to receive Structural Soil by calling New York City/Long Island Call One Center, (800) 272-4480. The Contractor shall be liable to repair any damage to underground utilities or structures caused by their activity during the progress of this work, at their own expense. Where tree roots larger than one inch (1") diameter are damaged, the Contractor shall ensure that damaged root sections are cleanly cut with sterilized pruning equipment.

Prior to placing pavement, the licensed CU-Soil™ provider and the Forester shall check the Structural Soil material for consistency with the color and texture of the approved sample supplied by the Contractor. In the event that the material supplied varies significantly from the approved sample, the Forester may request that the Contractor test the installed Structural Soil. Any mix which varies significantly from the approved testing results, as determined by the Forester, shall be removed and new Structural Soil installed that meets the specifications.

License: You are required to use a licensed CU Structural Soil manufacturer.

2. Plant Pest Control Requirements

You are reminded to comply with Federal and State Department of Agriculture regulations for plant pest control. Full information can be obtained from Federal and State Pest Control personnel.

A. ASIAN LONGHORNED BEETLE

Quarantine zones for the Asian Longhorned Beetle currently cover large areas of Brooklyn, Manhattan, Queens, and part of Staten Island. You must read and understand the nature and area of the quarantine as presented in Rule Making Activities, New York State, Department of Agriculture & Markets, Emergency Rule Making (Asian Longhorned Beetle; I.D. No. AAM - 53

96 00016 - E). You shall become familiar with restrictions and regulations established by all authorities having jurisdiction.

Anyone working within the Quarantine Zone must have certification from the New York State Department of Agriculture and Markets to do so. In general, State Department of Agriculture regulations requires contractors operating in infested areas to thoroughly clean all equipment units before moving them to non-infested areas.

Tree species listed as hosts for the Asian Longhorned Beetle are generally prohibited from planting within all of Brooklyn, Manhattan, Queens, and parts of Staten Island. Exceptions will be made on a case-by-case basis with the approval of the Parks Forester.

3. Materials

A. PLANTS

- a. *Digging.* All trees shall be dug immediately before moving unless otherwise specified. All trees shall be dug to retain as many fibrous roots as possible. Balled and burlapped trees shall have a solid ball of earth of the minimum specified size (28”), securely held in place by untreated burlap and stout rope (nylon rope is NOT acceptable). Oversize or exceptionally heavy trees are acceptable if the size of the ball or spread of roots is proportionally increased. Loose, broken, or manufactured balls are unacceptable. Size and grading standards shall conform to those of the American Association of Nurserymen American Standards for Nursery Stock, 1996 Edition, unless otherwise specified.
- b. *Form and structure.* All trees shall be typical of their species or cultivar. They shall have normal, well developed branches and a fibrous root system. They shall be sound, healthy, vigorous trees, free from defects, disfiguring knots, sunscald, injuries, abrasions of the bark, plant diseases, insect eggs, borers and all forms of infestations. All trees shall have a single, straight trunk, with leader intact (not all species have a leader but one must be present in those that do) and be branched at least five feet from the ground.
- c. *Provenance and tree size.* All trees shall be nursery grown in a USDA hardiness zone of 7B or lower (material collected from the wild is unacceptable), except with permission from Parks. Tree size shall be at least 2.5 inch caliper measured at six inches from the ground and no larger than 3.5 inches in caliper unless otherwise authorized by Parks & Recreation.
- d. *Plant names.* Plant names shall agree with the nomenclature of “Standardized Plant Names” as adopted by the American Joint Committee on Horticultural Nomenclature 1942 edition. All tree cultivars, patented or otherwise must be certified by the supplying nursery. All nurseries shall be required to have a registration certificate from the Department of Agriculture & Markets, Division of Plant Industry, New York State certifying that plant material is apparently free from injurious insect and plant diseases. A similar certificate shall be required from other states where plant material is obtained.
- e. *Species selection.* Species shall be selected from the list of approved Street Trees for New York City. Guidelines on this chart must be followed, as well as any conditions described on the permit. Restrictions may include species recommended for specific planting seasons and locations. Ultimately, it is Parks decision what species of tree will be planted. Take special note of species prohibited from planting in Brooklyn, Manhattan, Queens, and parts of Staten Island due to the Asian Longhorned Beetle.

B. BACKFILL

Material shall consist of natural loam topsoil with the addition of humus only, and no other soil type, such as a sand or clay soil type, shall be accepted. Topsoil must be free from subsoil, obtained from an area which has never been stripped. It shall be removed to a depth of one (1) foot, or less if subsoil is encountered. Topsoil shall be of uniform quality, free from hard clods, stiff clay, hardpan, sods, partially disintegrated stone, lime, cement, ashes, slag, concrete, tar residues, tarred paper, boards, chips, sticks or any other undesirable material. If a truckload of topsoil is considered by the Agency to contain too much undesirable material to be corrected on the site, the entire truck load shall be rejected. No topsoil shall be delivered in a frozen or muddy condition. Topsoil shall comply with the following requirements:

- a. *Organic Matter.* Must be between seven (7) and twelve (12) percent (not to exceed 14 percent) by weight, as determined by the Dry Combustion Method for Total Carbon and Organic Carbon (using a multiplying factor of 2) as described in Methods of Soil Analysis, #9, Part 2, 2nd ed. published by the American Society of Agronomy. The organic content shall not exceed fourteen percent (14%).
- b. *pH range.* Shall be 6.0 to 7.0 inclusive.
- c. *Sieve Analysis* (by Wash Test, ASTM Designation C-117). Passing 2" sieve (100%); Passing 1" sieve (95% to 100%); Passing #4 sieve (90% to 100%); Passing #100 sieve (30% to 60%).
- d. *Clay.* The test method to measure the clay content of the soil shall be ASTM D 422.

The Parks Forester reserves the right to reject topsoil in which more than 60% of the material passing the No. 100 U.S.S. Mesh sieve consists of clay as determined by the Buoyoucouc Hydrometer or by the decantation method. All percentages are to be based on dry weight of sample. When the topsoil otherwise complies with the requirements of the specification but show a deficiency of not more than one (1) percent in organic matter, it may be incorporated when and as permitted by the Forester. Electrical Conductivity shall be less than 0.5 mhos/cm. A higher level would indicate excessive salt content.

At final inspection if soil does not appear to meet specifications you will not receive a final sign-off of your permit. If directed, topsoil which varies only slightly from the specifications may be made acceptable by such corrections as the Inspector deems necessary.

C. MULCH

Shredded bark mulch shall be a natural forest product of 98% bark containing less than 2% wood or other debris. It shall be of White or Red Fir and/or Pine bark of a uniform grade with no additives or any other treatment. Size of bark shall be from 5/8" to 1-1/4".The pH factor should range from 5.8 to 6.2. Shredded bark may also be used.

D. WATER

If conditions do not allow the use of New York City water sources, you must obtain your own source of water.

4. Planting Specifications

Planting shall consist of excavating all tree pits, planting, and maintaining new trees of the type and size designated on the approved list. All work shall be in accordance with these specifications and to the satisfaction of the Parks representative.

If any new tree pits have to be cut, a permit must first be obtained from the Department of Transportation. A permit shall be required for each block where the pavement is broken for a new pit. It is your responsibility to notify all owners/operators of underground facilities (code 753). Owners/operators of underground facilities include but are not limited to Keyspan, Con Edison and telephone authorities. Code 753 notifications are to be made to the NYC/LI One Call Center, Briarwood Plaza, Suite 202, 36-35 Bell Boulevard, Bayside, NY 11361. Telephone No. 1-800-272-4480. A code 753 number must be obtained before any work can begin.

No pits shall be dug until proposed locations have been marked on the ground with a white 'P' by Parks & Recreation staff. Once work begins you take full responsibility for the tree pit locations. All excavated materials shall be removed from the site and disposed of. The area is to be made safe and secure at the end of the workday.

Site characteristics, such as overhead power lines, existing vegetation, and infrastructure items, such as curbs and sidewalks, shall be considered. Trees that grow taller than 25 feet should not be planted directly under power lines. When possible the tree leader shall be offset from power lines.

Where subsurface obstructions (vaults, utilities, sprinklers) are encountered during excavation, and restrict the planting of a tree you shall restore the disturbed area to its original condition. If damage is done to an underground obstruction it is the responsibility of the contractor to restore the site to its original condition. A new planting location will be designated if conditions permit.

Trees shall be transported and handled with utmost care to insure adequate protection against injury and desiccation. When transported in closed vehicles, plants shall receive adequate ventilation to prevent sweating. When transported in open vehicles, plants shall be protected by tarpaulins or other suitable cover material. Balled and burlapped trees shall be set on the ground and balls covered with soil. Until planted, all materials shall be properly maintained and kept adequately watered. You are liable for any damage to property caused by planting operations and related work. **All disturbed areas shall be restored to their original condition.**

You are only permitted to occupy an eight-foot lane adjacent to the curb. Traffic shall not be blocked off at any time during planting operations. Work shall not be performed on opposite sides of the street at the same time. Existing parking regulations shall be complied within so far as "No Standing" rules apply for the time limits specified.

A. PLANTING SEASONS

Trees may be planted in the fall from October 1st through December 31st and in the spring from March 1st through May 31st. No planting is permitted in the summer. Please be aware of the DOT Construction Embargo from November 21st thru January 2nd (Street may vary from year to year, please check DOT's website).

B. INSTALLATION

Remove all materials from the tree pit for the full length and width of the tree pit to the depth of the tree's root ball (see diagram pg. 13 Tree Planting and Stake Detail). For excavation of a tree lawn, excavate an area at least three times the diameter of the root ball in length by the width of the lawn strip (up to three (3) times the diameter of the rootball), to the dimensions listed on the permit. Extreme care shall be taken not to excavate to a depth greater than required. The subgrade below the root ball shall be tamped slightly to prevent settlement. All ropes, stones, etc. shall be removed from the planting site before backfilling. All excavated materials shall be removed from the site and disposed of.

Place balled and burlapped material in the prepared planting pit by lifting, and carrying it by the rootball so that the ball will not be loosened. Set the tree straight and in the **center of the pit**. All trees shall sit, after settlement, with the base of the trunk and the beginning of the roots known as the "trunk flare" level with the sidewalk grade. If the top of the rootball is not consistent with this area, soil will be added or removed below the rootball to make it so, and the depth of the planting site adjusted accordingly.

Cut and remove rope and wire from the top 2/3 of the rootball. At least 2/3 of the burlap shall be removed from the tree pit. The remaining wires should be pulled back and the burlap adjusted to prevent the formation of air pockets. Backfilling mixture shall be loose and friable, and not frozen. Soil shall be firmed at six to eight inch intervals. All tree pits are to be filled with topsoil or backfill and made level with existing conditions.

Cultivate and rake over finished planting areas leaving them in an orderly condition. On level ground or slight slopes, a shallow basin a little larger than the diameter of the tree ball shall be left around each tree. At no time should topsoil be mounded to cover the trunk of the tree. **The trunk flare shall always be visible**. Final soil level, except for the shallow basin, shall be flush with the surrounding sidewalk grade to prevent potential tripping hazard.

C. TREE WRAP

No tree trunks shall be wrapped. Remove all nursery tags and protective wrapping.

D. STAKING

All staking shall be done during planting operation and shall be maintained throughout the first year of the two (2) year guarantee period.

Stakes shall be of white cedar with bark attached and shall show no sign of cracking or decay. They shall have a maximum allowable deflection of ten percent (10%). Stakes shall be cut even so they are the same height. All trees shall be supported by two (2) stakes, they shall be eight (8) feet long; the diameter at the middle shall be not less than (2) inches nor more than two and three quarters (2-3/4) inches and the diameter at the butt shall not exceed three (3) inches. Stakes shall be placed outside of the rootball, driven thirty (30) inches into the ground, and shall be fastened to the tree with a suitable length of 3/4" wide, flat, woven polypropylene material such as Arbortie™ as manufactured by DeepRoot®, San Francisco, CA or approved equal that is knotted around the tree stakes.

Unless otherwise directed, trees shall be staked as shown on the plans and in accordance with these specifications. Stakes shall be set parallel to curbs. Trees shall stand plumb after staking. Stakes and Arbortie™ shall be removed at the end of the first year of the two (2) year guarantee period, unless directed otherwise by the Project Manager. At the time the stakes are removed any holes left by the stake shall be filled with topsoil of the same quality as that specified in Section B- Backfill.

E. PRUNING

Only crossing, dead, broken or badly bruised branches shall be removed. These shall be pruned with a clean cut. All pruning shall be done with sharp pruning tools. At the time of planting, pruning cuts shall be made at the base of the branch at such a point and angle that neither the branch collar nor the bark of the stem is damaged, and that no branch stub extends from the collar. Crowns of young trees shall not be cut back to compensate for root loss. No leaders shall be cut.

F. WATERING

At the time of planting, the soil around each tree shall be thoroughly saturated with at least twenty gallons of water. Soil shall be firmed at six to eight inch intervals and thoroughly settled with water. Water shall be free from oil, have a pH not less than 6.0 nor greater than 8.0 and shall be free from impurities injurious to vegetation. Water may be drawn from mains owned by or supplying water to the City of New York. Please contact DEP for an access permit.

Water shall not be applied in a manner which damages plants, plant saucers, stakes or adjacent areas. Each plant saucer shall be carefully filled with water in a manner which does not erode the soil or the plant saucer. Watering shall not cause uprooting or exposure of plant's roots to the air.

G. MULCHING

Bark Mulch shall be applied as a ground cover to the surface of all planting beds at the time of planting and again after the tree stakes have been removed, one year after planting. (See Section 3 C for Mulch specifications).

Mulch shall be applied to a uniform depth of three (3) inches and shall be so distributed as to create a smooth, level cover over the exposed soil. A gap of approximately 2" should be left between the mulch and the trunk of the tree to avoid mounding above the trunk flare.

5. Seasonal Maintenance

A. WATERING

Watering shall also take place throughout the two (2) year guarantee period, at least 20 gallons at approximately two week intervals from May 15 to October 31. You may need to increase or reduce the frequency of watering based on weather conditions, resulting soil water content or other factors.

Water shall not be applied in a manner that damages plants, plant saucers, stakes or adjacent areas. Each plant saucer shall be carefully filled with water in a manner that does not erode the soil or the plant saucer. Watering shall not cause uprooting or exposure of plant's roots to the air. Damages resulting from these operations shall be immediately repaired at your expense.

B. OTHER MAINTENANCE ACTIVITIES

All newly planted trees shall be maintained until two (2) years after the final inspection of permitted planting.

Maintenance shall include weeding, cultivating, edging, pruning, adjustment and timely removal of stakes, and Arbortie™ (these must be removed after one year), repair of minor washouts, mulching, soil replacement and other horticultural operations necessary for the proper growth of all trees, and for keeping the entire area within the planting area neat in appearance.

All planting areas shall be cultivated and weeded with hoes or other approved tools within the period from May 15th to October 31st, and such cultivating and weeding shall be repeated at least every three (3) weeks. Under no conditions shall weeds be allowed to attain more than six (6) inches of growth.

Pit pavement shall be maintained flush with adjacent pavement during the two (2) year guarantee period. At the expiration of the guarantee period the area around the tree shall be cultivated and weed free.

6. Guarantee Period

All trees must be guaranteed for two (2) years. All legitimate contractors and nurseries provide a guarantee for their trees. Make sure to confirm the two (2) year guarantee, and beware of suppliers who claim not to provide this service.

A. TREE REPLACEMENT

Any planted tree that is dead or, in the opinion of the Parks Department, is in an unhealthy or unsightly condition, and/or has lost its natural shape due to dead branches, excessive pruning, inadequate or improper maintenance, or other causes including vandalism, prior to final acceptance, shall be replaced in the next planting season. There shall be a two (2) year guarantee on trees commencing after the final inspection of the permitted planting. The topsoil in the tree pit shall be changed when any replacement tree is planted.

Where dead trees have been identified, whether due to natural causes or vandalism, the dead material shall be removed, including stakes, and Arbortie™ **within 30 days of notification.** When necessary, topsoil, grass seed or appropriate paving material shall be added to the pit to eliminate potential tripping hazards at the time of removal. You must submit photos to Parks showing the proper removal of trees. You must then obtain a permit to replant during the planting season.

B. VANDALISM

Where vandalism or related causes are agreed as the cause for tree replacement, you shall be responsible for one replacement during the two (2) year guarantee period after final inspection of the permitted planting. It will be necessary to prove that the tree was vandalized using photo-documentation.

7. Finishing

Paving blocks, installed in the manner described below are required within each sidewalk tree pit when specified by Parks. Exceptions to this requirement are allowed on a case by case basis. Examples include adequate tree pit guards or non-invasive or competitive under plantings. Please note that Parks will take action if the tree guard, under planting, or paving endangers the long-term health and survival of city-owned trees. Parks does not allow tree grates to be installed around newly planted or existing trees.

A. PAVING BLOCKS

a. Materials

Granite Block Pavers: Granite blocks shall be new or used and shall be cut from fine to medium grained sound and durable granite. The granite shall be reasonably uniform in quality and texture throughout and shall be free from an excess of mica and feldspar and from seams, scales or evidence of disintegration. If used blocks are utilized they shall be clean, free from mortar, asphalt, etc.

Blocks shall be fairly rectangular in shape and shall be not less than four (4) inches nor more than twelve (12) inches in length; not less than three (3) nor more than five (5) inches in width; not less than three (3) nor more than five (5) inches in depth. The blocks shall be cut so that opposite faces will be approximately parallel and adjoining

faces approximately at right angles to each other. Granite blocks shall be so dressed that they may be laid with one (1) inch joints. All blocks shall have one reasonably smooth split head.

b. Installation

Paving blocks shall be installed using a sand cushion. The sand shall consist of clean, hard, durable, uncoated stone particles, free of lumps of clay and all deleterious substances and shall be so graded when dry, one hundred percent shall pass a ¼ inch square opening sieve; not more than thirty-five percent by weight shall pass a No. 50 sieve. Sand shall conform to ASTM C-33.

Trim and tamp the subgrade to smooth, uniform lines prior to placing the pavers. The pavers shall be laid on a sand cushion with a minimum thickness of one inch. The sand cushion shall be compacted by hand tamping, or as directed by the Forester. Joints between pavers shall be a maximum of one inch and a minimum of three quarters inch in width. All joints (inner and outer) shall be mortared in place with a cement mortar of a wet mixture of one part Portland cement and two parts sand. (see drawing page 21-22)

Care should be taken to leave a maximum amount of tree pit surface area uncovered, without pavers (see drawing pg 20 & 21). The installation of tree guards shall not interfere with the proper grade of the tree; trees cannot be planted deeper to accommodate pavers and root balls cannot be damaged during installation.

B. TREE PIT GUARDS

Tree pit guards are not required by Parks. A tree pit guard is a device, usually a cast-iron fence or wrought-iron wickets, installed around a tree pit for protection. Parks recommends a low cast-iron fence or wrought-iron wickets that is 18" high. Tree guard posts shall be solid steel. Tree guards should be three sided leaving the street side open and should **not** be embedded into concrete. This will protect the tree from dogs and pedestrians and give it enough space to grow for many years to come. New York City Parks has four standardized and approved designs which are encouraged for all tree guard installations. See Appendix for specifications. Please also note that the permittee takes full responsibility for maintaining the tree guard in a safe condition. If the condition of the tree guard is not maintained in a safe condition the tree guard will be removed by NYC Parks.

Interested parties should apply for a permit to work on or near a tree before installing a tree guard. The permit is to 'Install Tree Guard'. Guards should not be installed close to tree trunks, and should be installed along the perimeter of three sides of the tree bed. They strangle the tree as it grows and fail to protect the root zone.

Sidewalk-level tree grates are not permitted; granite paving should be used as an alternative. Grates do not protect the tree trunk and the tree will grow into them and die if the openings are

not periodically widened. They also serve as receptacles for litter and if raised by the tree's growth will cause a trip hazard.

Do not install brick or concrete walls around the tree pits. The interior space created by the solid wall encourages property owners to add soil over the root zone for plantings, unwittingly suffocating tree roots.

Never plant Ivy or woody shrubs/plants in the tree pit as they compete with the tree for vital nutrients.

APPENDIX

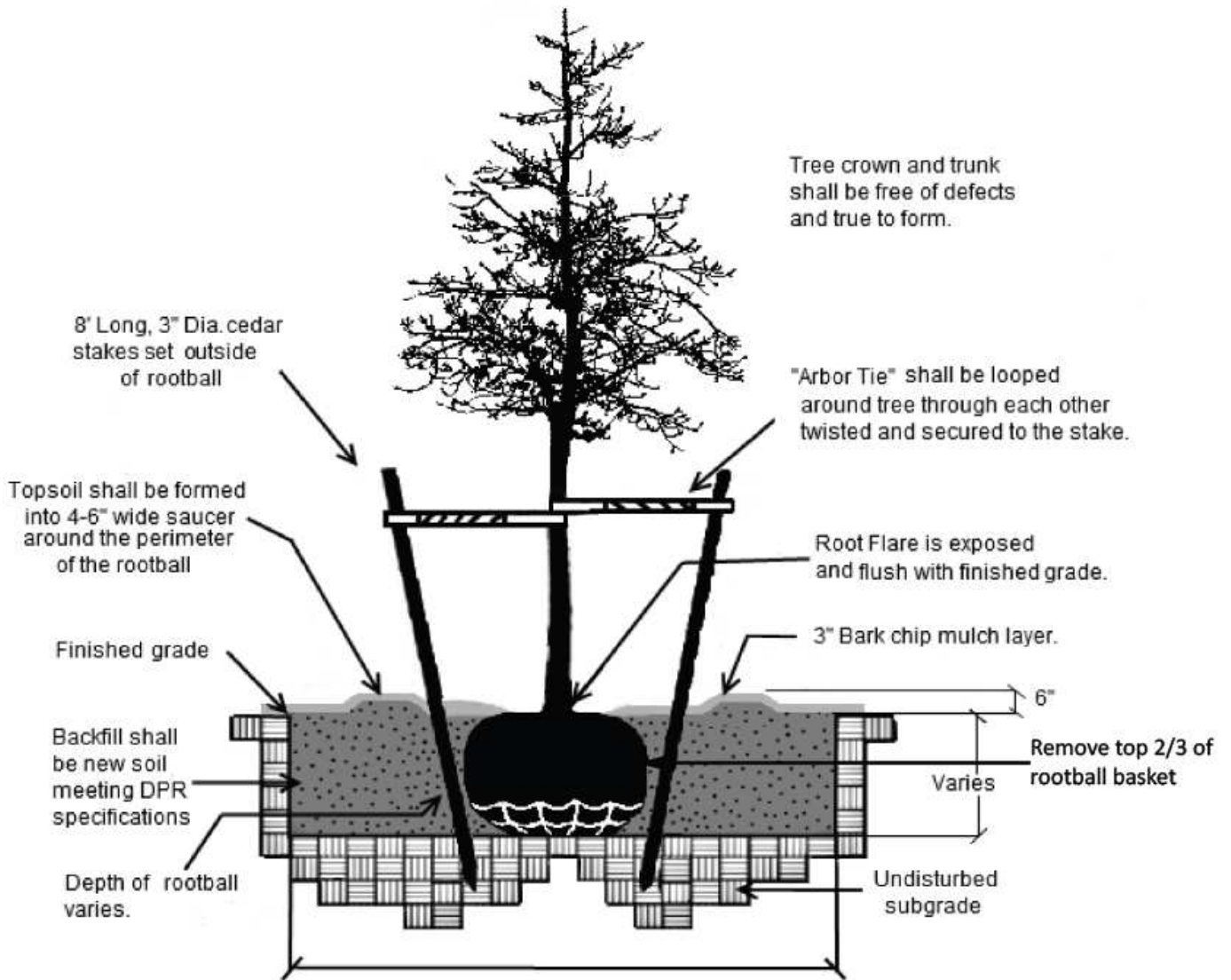

Tree Planting & Stake Detail

Not to Scale

SAMPLE TREE PIT CONFIGURATIONS

TREE PIT DIMENSIONS*			
	Length (ft)	Surface Area (sf)	Soil Volume (cu ft)
Width: 7 ft			
	6	42	84
	7	49	98
	8	56	112
	9	63	126
	10	70	140
	⋮	⋮	⋮
	25	175	350
	⋮	⋮	⋮
	50	350	700
	⋮	⋮	⋮
	100	700	1400
Width: 6 ft			
	6	36	72
	8	48	96
	9	54	108
	10	60	120
	⋮	⋮	⋮
	25	150	300
	⋮	⋮	⋮
	50	300	600
	⋮	⋮	⋮
	100	600	1200
Width: 5 ft			
	6	30	60
	7	35	70
	8	40	80
	9	45	90
	10	50	100
	⋮	⋮	⋮
	25	125	250
	⋮	⋮	⋮
	50	250	500
	⋮	⋮	⋮
	100	500	1000
Width: 4 ft			
	7	28	56
	8	32	64
	9	36	72
	10	40	80
	⋮	⋮	⋮
	25	100	200
	⋮	⋮	⋮
	50	200	400
	⋮	⋮	⋮
	100	400	800

*all calculations based on a tree pit depth of 2 feet. In general, tree pit depth should match root ball height. In the case of structural soil, pit can be deeper.

Notes:

These dimensions illustrate the variety of tree pit sizes and configurations that are possible. They are not meant to be fixed. Tree pits should always be as large as possible. The larger the soil volume the larger the tree size will be at maturity and the better chance it has for long-term survival.

The longer tree pit lengths on the chart at left show the soil volumes achieved in continuous tree pits, which are underground trenches that are generally treated with structural soil belowground and sidewalk pavement aboveground, except for the area around the tree which resembles the open area of a traditional tree pit.

General rules for proximity to built infrastructure:

- 20 feet from light poles
- 30 feet from stop signs
- 6 feet from traffic signs
- 5 feet from parking meters
- 2 feet from water drains
- 2 feet from utilities
- 5 feet from hydrants
- 7 feet from driveways
- 39 inches minimum passage for ADA considerations
- 5 feet passage general requirement NYC DOT
- 15 to 25 feet from other trees

Note: these are general infeasibility criteria meant to guide designers. Specific rules and allowances will be established during the DPR permitting process, since exact tree siting varies by tree species selection, local site conditions, and other agency requirements.

Prepared by DPR, Central Forestry & Horticulture, May 2008

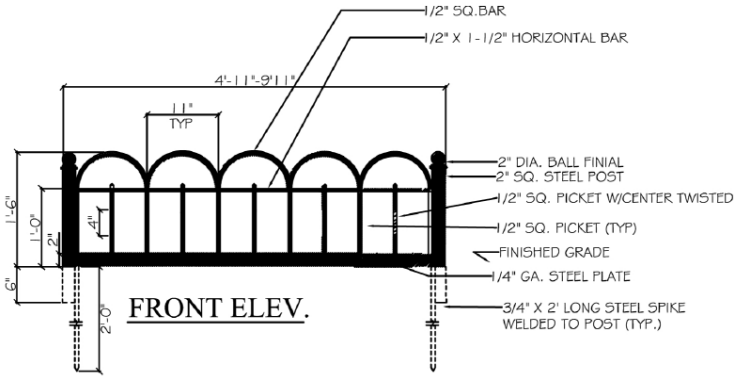

TREE PIT GUARD TYPE 'A'

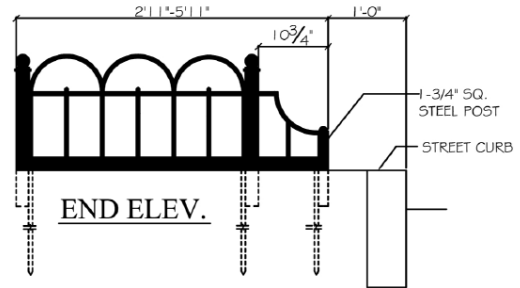

TYPE 'A' THREE SIDED DESIGN

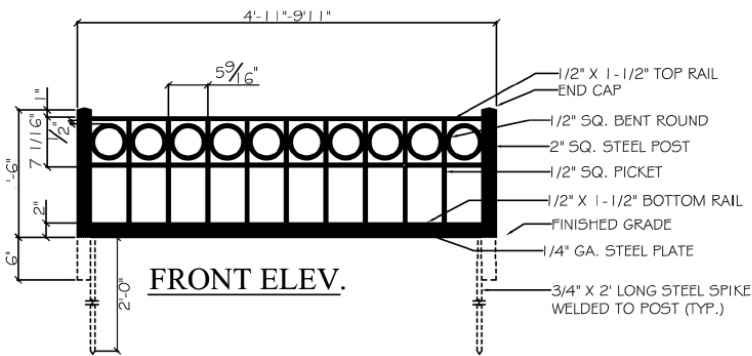

TREE PIT GUARD TYPE 'B'

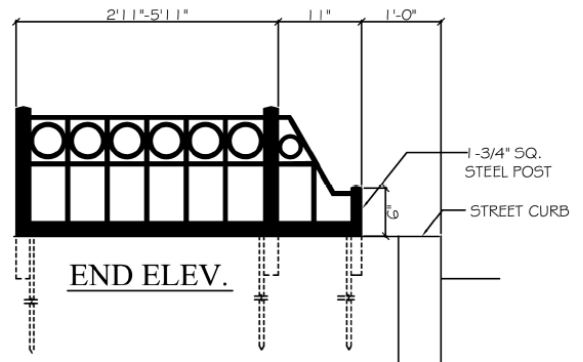

TYPE 'B' THREE SIDED DESIGN

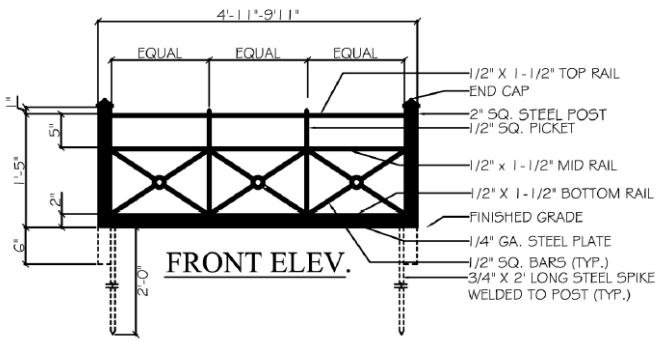

TREE PIT GUARD TYPE 'C'

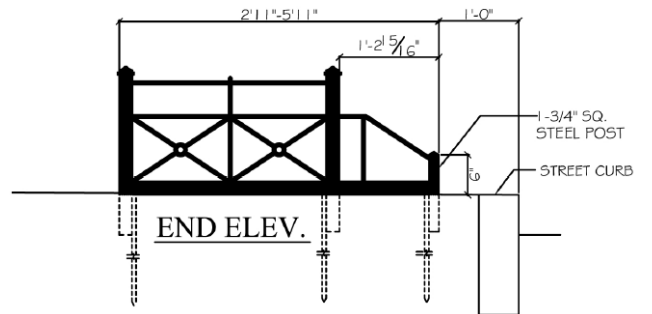

TYPE 'C' THREE SIDED DESIGN

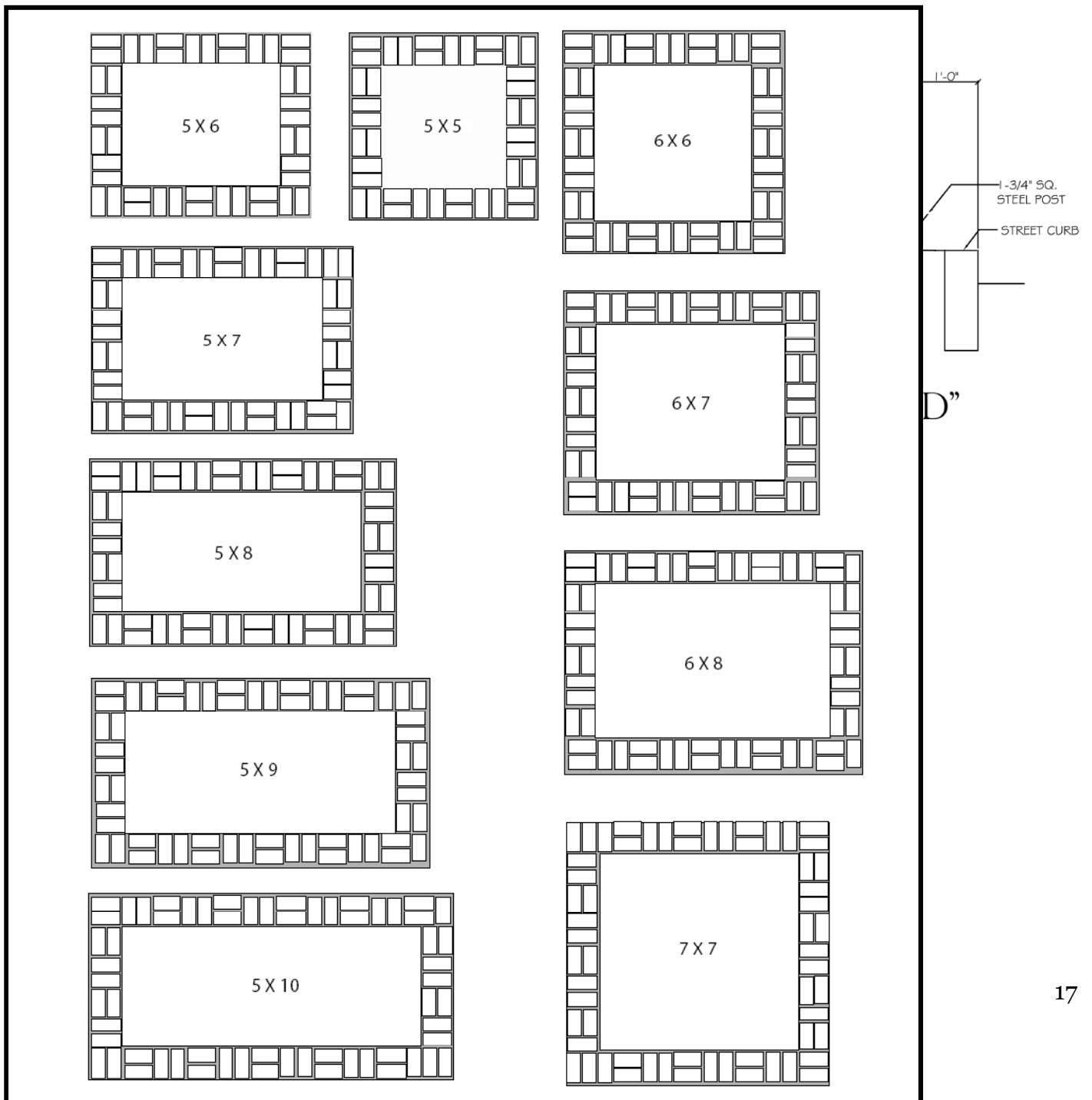

Tree Pit Dimensions and Paving Standards



APPENDIX four

NYC DPR
TREE PLANTING
STANDARDS II

Street Tree Planting Standards for New York City 2016



City of New York
Parks and Recreation

NYC Parks

Table of Contents

- Table of Contents** 2
- Overview** 4
 - Street Tree Planting Requirements for New Buildings 4
- Design Requirements** 5
 - Spacing Requirements 5
 - Tree Pit Dimensions 5
 - Grouped Plantings 6
 - Species Selection 6
 - Structural Soils 6
 - Soil Cells (Silva Cells) 6
 - Permeable Pavement or Pavers 6
 - Bioswales / Green Infrastructure 7
- Plant Pest Control Requirements** 7
 - Asian Longhorned Beetle 7
- Materials** 7
 - Plants 7
 - Backfill 8
 - Mulch 9
 - Water 9
- Planting Specifications** 9
 - Planting Seasons 10
 - Installation 10
 - Tree Wrap 11
 - Staking 11
 - Pruning 11
 - Watering 12
 - Mulching 12
- Seasonal Maintenance** 12
 - Watering 12
 - Other Maintenance Activities 12

Guarantee Period 13

Tree Replacement 13

Vandalism 13

Finishing 13

Tree Pit Guards 13

Tree Grates 14

Pavers 14

Other 14

APPENDICES 15

Appendix A 15

Appendix B 19

Appendix C 22

Appendix D 24

Appendix E 30

Appendix F 31

Important Note: All permit holders are expected to be familiar with and to plant in accordance with NYC Parks Standards. Detailed Parks approved specifications may be available. Ask your NYC Parks Forester for further details when applying for or requesting a permit. All permit request must be made using the new *Tree Work Permit and Plan Review Application* found at the following link:

<https://www.nycgovparks.org/services/forestry/forestry-application>

Introduction

The mission of Forestry, Horticulture, and Natural Resources is to protect, restore, expand and manage New York City's green spaces and natural areas to maximize the benefits for environmental and community health and resilience.

Overview

Street trees are important to our quality of life in the city. They are living elements of our street infrastructure. Located on the public right-of-way, they provide cooling shade, cleaner air, and more beautiful urban streetscapes. Trees confer important aesthetic and ecological benefits to city residents as well. Plants in the urban landscape, however, face a variety of environmental and physical stresses including pedestrian and vehicular traffic, soil compaction, air pollution, and drought. Some of the key factors to maximize long-term plant survival are proper handling, careful planting, and immediate and continued aftercare.

All trees planted on the public right-of-way are under the jurisdiction of the Department of Parks & Recreation as property of the City of New York. A valid tree planting permit must be obtained in order to plant on the public right-of-way, and plantings must be done in accordance with the agency's current street tree planting standards. Any tree work improperly performed or otherwise not in accordance with these specifications may be subject to remedial work at the tree work entity's expense, and/or additional penalties.

Street Tree Planting Requirements for New Buildings

All new buildings and all enlargements exceeding 20 percent of the floor area must provide one new street tree for every 25 feet of building road frontage. These requirements must be satisfied for the builder to obtain a Certificate of Occupancy from the Department of Buildings (DOB). All jobs pre-filed with DOB after May 3, 2010 are required to undergo a Parks Plan Review before any permits or tree fund invoice can be issued.

Design Requirements

Spacing Requirements

The following requirements shall be followed when siting tree pits along sidewalks. These guidelines generally follow regulations of other agencies with jurisdiction or infrastructure on the right-of-way. These requirements are design and tree species dependent. The *American with Disabilities Act* (ADA) guidelines must also be followed.

- a. Do not plant in front of building entrances in order to permit easy access by the Fire Department.
- b. Do not plant within bus stops.
- c. Do not plant within no standing zones
- d. Do not plant directly over DEP water mains less than 20 inches in diameter.
- e. Minimum horizontal distance from DEP water main to tree trunk is 6 feet.
- f. Minimum distance between trees (trunk to trunk) shall be 20 feet to 30 feet, depending upon the tree species and other local conditions.
- g. Minimum distance from a streetlight or utility pole to the tree trunk is 25 feet (this may vary with tree species).
- h. Minimum distance from a stop sign to the tree trunk is 30 feet.
- i. Minimum distance from other traffic signs to the tree trunk is 6 feet.
- j. Suggested distance from a parking meter back to tree trunk shall be no more than 5 feet, to allow for the swing of car doors.
- k. Minimum distance from a gas or water valve to the edge of the pit is 2 feet.
- l. Minimum distance from an oil fill pipe to the edge of the pit is 4 feet.
- m. Minimum distance from the edge of a coal chute to the edge of the pit is 2 feet.
- n. Minimum distance from a fire hydrant to the edge of the pit is 3 feet.
- o. Minimum distance from a curb cut or driveway to the edge of the pit is 2 feet and to the tree trunk is 7 feet.
- p. Minimum distance from the corner of a street intersection to the tree trunk is 40 feet.
- q. Minimum distance from the edge of the pit to any opposite obstruction (building wall, stoop, railing, property line etc.) is from 4 to 6 feet, depending upon local conditions and the amount of sidewalk traffic.
- r. All tree pits must be contiguous to the street curb (except as noted below, or with the permission of the Forester).
- s. Trees may be planted on either side of sidewalks (if any exist) in lawn areas where there is sufficient room between the property line and the street curb.

Additional design or spacing requirements may be imposed at the discretion of the Parks Forester reviewing your application depending on the location and site conditions.

Tree Pit Dimensions

Tree pits should be as large as possible to allow for ample growing space for the tree's roots and to reduce the likelihood of future sidewalk lifting. The standard street tree pit size is 5 feet by 10 feet. The overall width of a sidewalk can limit the size of a tree pit. Where a 5 feet by 10 feet tree pit is not possible, alternate dimensions must be approved by the Forester.

The installation of continuous tree pits is encouraged whenever possible, and design proposals that call for continuous tree pits may be given more flexible spacing requirements by the Forester.

Grouped Plantings

Grouped plantings are sites where trees are planted closer than 20 feet from each other (trunk to trunk). Grouped plantings provide a number of environmental benefits which include: increased shading, reduced evapotranspiration, reduced soil compaction, greater available soil volume, and reduced exposure to reflective heat for an individual tree. A grouped planting can be achieved in several types of sites: (1) a GreenStreet, such as a median or traffic triangle, with opportunity for a large planting bed; (2) a continuous tree pit, where two or more trees are planted in a single trench in the sidewalk (at least 30 feet long); or (3) a raised planting bed within a plaza or alongside a pedestrian passageway. Grouped plantings are not often the preferred method of planting and are subject to approval at the discretion of the Forester reviewing your proposal.

Species Selection

Growing conditions and microclimates can vary from location to location within a borough and across the City. Species selection should take into account site conditions, design goals, and diversity goals. In choosing a species, the mature height and spread shall be considered to ensure that it will not interfere with existing or proposed structures and overhead utilities. The final selection of the species is made by the Forester. Parks will not allow large trees to be planted under primary wires and discourages small trees in large open spaces. NYC Parks publishes a list of approved species for planting on the right-of-way. (Appendix A). Alternate species not found on the approved list may be considered on a case by case basis, however, NYC Parks retains the right to determine what species is planted on the right-of-way.

Structural Soils

NYC Parks encourages the use of structural soils where appropriate, and may require its use where it is deemed necessary. Trees are not to be planted directly in structural soil, and structural soil is only to be used as a base material under hard surfaces such as concrete, permeable pavement, or permeable pavers. Exposed soil or grass covered surfaces should be excavated and replaced with fresh topsoil meeting DPR street tree planting specifications. NYC Parks has approved the use of CU and Swedish Structural Soils, and they must be installed in accordance with Parks' specifications (Appendix B). Structural soils can only be installed with the prior consent of the Parks Forester reviewing your application and the use of a licensed structural soil manufacturer is required.

Soil Cells (Silva Cells)

Soil cells such as Silva Cells, may be used where appropriate. They can only be installed with the prior consent of the Parks Forester reviewing your application, and must be installed in accordance with Parks' specification (Appendix C).

Permeable Pavement or Pavers

NYC Parks encourages the use of permeable pavement or pavers where appropriate to increase the amount of water available to trees and to assist in storm water capture and management. All pavement or pavers must conform to Department of Transportation (DOT) standards (Refer to DOT for materials and specifications). Parks may approve or require the placement and use of

permeable pavers or pavement around new and existing trees. The proposed use of permeable pavers or pavement should be noted in the permit application.

Bioswales / Green Infrastructure

Bioswales installed on the right-of-way help collect and manage storm water runoff from streets and sidewalks by directing storm water to engineered systems that typically feature soils, stones, and vegetation. At this time, Parks does not issue permits for private installations of bioswales on the right-of-way without the consent of appropriate city agencies, and provisions for maintenance in place.

Plant Pest Control Requirements

Any planting on the public right-of-way is required to comply with all state and federal regulations for plant pest control. More information can be obtained from the appropriate state and federal pest control agencies.

Asian Longhorned Beetle

Quarantine zones for the Asian Longhorned Beetle currently cover areas of Brooklyn and Queens. Applicants must read and understand the nature and area of the quarantine as presented in *Rule Making Activities, New York State, Department of Agriculture & Markets, Emergency Rule Making (Asian Longhorned Beetle; I.D. No. AAM - 53 96 00016 - E)*. The applicant shall become familiar with restrictions and regulations established by all authorities having jurisdiction.

Anyone working within the Quarantine Zone must have certification from the New York State Department of Agriculture and Markets to do so. State Department of Agriculture regulations requires that applicants operating in infested areas to thoroughly clean all equipment units before relocation to non-infested areas.

Parks imposes restrictions on the planting of tree species listed as hosts for the Asian Longhorned Beetle in parts of Brooklyn and Queens. Exceptions may be considered on a case-by-case basis.

Materials

Plants

Digging. All trees shall be dug immediately before moving unless otherwise specified. All trees shall be dug to retain as many fibrous roots as possible. Balled and burlapped trees shall have a solid ball of earth of the minimum specified size (32 inches), securely held in place by untreated burlap and stout rope (nylon rope is NOT acceptable). Oversize or exceptionally heavy trees are acceptable if the size of the ball or spread of roots is proportionally increased. Loose, broken, or manufactured balls are unacceptable. Size and grading standards shall conform to those of the *American Association of Nurserymen American Standards for Nursery Stock, 1996 Edition*, unless otherwise specified.

Form and structure. All trees shall be typical of their species or cultivar. They shall have

normal, well developed branches and a fibrous root system. They shall be sound, healthy, vigorous trees, free from defects, disfiguring knots, sunscald, injuries, abrasions of the bark, plant diseases, insect eggs, borers and all forms of infestations. All trees shall have a single, straight trunk, with leader intact (not all species have a leader but one must be present in those that do) and be branched at least five feet from the ground unless otherwise specified or approved by the Forester.

Provenance and tree size. All trees shall be nursery grown in a USDA hardiness zone of 7B or lower (material collected from the wild is unacceptable), except with permission from Parks. Tree size shall be at least 2.5 inch caliper measured at 6 inches from the ground and no larger than 3.5 inches in caliper unless otherwise authorized by NYC Parks.

Plant names. Plant names shall agree with the nomenclature of “Standardized Plant Names” as adopted by the American Joint Committee on Horticultural Nomenclature 1942 edition. All tree cultivars, patented or otherwise, must be certified by the supplying nursery. All nurseries shall be required to have a registration certificate from the Division of Plant Industry of the New York State Department of Agriculture & Markets certifying that plant material is apparently free from injurious insect and plant diseases. A similar certificate shall be required from other states where plant material is obtained.

Species selection. Species shall be selected by Parks from the list of approved street trees for New York City (Appendix A). You may only plant the species indicated on the permit and must follow any terms and conditions described on the permit. Season, site conditions, and location will affect what species may be planted.

Backfill

Material shall consist of natural loam topsoil with the addition of humus only, and no other soil type, such as a sand or clay soil type, shall be accepted. Topsoil must be free from subsoil, obtained from an area which has never been stripped. It shall be removed to a depth of one foot or less if subsoil is encountered. Topsoil shall be of uniform quality, free from hard clods, stiff clay, hardpan, sods, particularly disintegrated stone, lime, cement, ashes, slag, concrete, tar residues, tarred paper, boards, chips, sticks or any other undesirable material. Topsoil shall meet the following requirements:

- a. *Organic Matter.* Backfill shall contain between 5%-9% organic matter.
- b. The pH shall be in the range of 6.0 to 7.5 inclusive, unless otherwise approved or specified by the Forester.
- c. *Soil Textural Analysis.* Topsoil shall consist of the following percentages of sand, silt and clay. Any soil that does not meet the requirements below will be rejected and removed from the site.

Rocks, Stone and Gravel (>2.0 mm)	<25%
Sand (0.05-2 mm)	40%-70%
Silt (0.002-0.05 mm)	10%-50%
Clay (<0.002 mm)	20% maximum
- d. When the topsoil complies with the requirements of the specification but show a deficiency of not more than one percent in organic matter, it may be incorporated when and as permitted by the Forester.
- e. Electrical conductivity shall be a maximum of 1.0. mmhos/cm. A higher level would indicate that the salt content is too high to be acceptable, and the soil must be removed from the site by the permit holder.

NYC Parks may require that soil be changed at the expense of the applicant and/or the tree work entity if the soil does not appear to meet Parks specifications. It is the applicant's responsibility to prove that the soil used meets Parks specifications. The applicant may provide a report from an approved lab showing a passing soil sample if they wish to show that their soil meets Parks specifications. The soil should be tested for the following: nutrients, pH, soluble salt level, organic matter content, percentages of sand/silt/clay, soil textural class, gravel content, + Extra Sieve ¼. The choice of lab must be approved in advance by the appropriate Parks Forester, and soil samples must be taken by a Parks Forester or their designate, and delivered to the lab by the Forester or their designate. Only a passing sample acceptable to the Parks Forester will exempt the applicant from having to replace the soil.

Mulch

The applicant shall furnish and place Shredded Bark Mulch in accordance with the plans, specifications and directions of the Forester. All mulching shall be done during planting operation.

Shredded Bark Mulch shall be a natural forest product composed of shredded bark or wood not exceeding 3 inches in length and 1 inch width. Mulch shall be derived from tree material, not from wood waste or by-products like sawdust, shredded palettes, or other debris. Mulch shall be natural in color and not dyed. It shall be of a uniform grade with no additives or any other treatment. Mulch with leaves, twigs, and/or debris shall not be acceptable.

Shredded Bark Mulch shall be applied as a ground cover to the surface of all planting beds at the time of planting, one year after planting when the tree stakes are removed, at the start of each watering season during the 2 year guarantee period and when the tree is watered when directed by the Forester. Shredded Bark Mulch shall be applied to a uniform depth of 3 inches and shall be so distributed as to create a smooth, level cover over the exposed soil. A gap of approximately 2 inches should be left between the Shredded Bark Mulch and the trunk of the tree to avoid mounding above the trunk flare.

Water

If conditions do not allow the use of New York City water sources, the applicant must obtain their own source of water.

Planting Specifications

Planting shall consist of excavating all tree pits, planting, and maintaining new trees of the type and size designated on the approved list. All work shall be in accordance with these specifications (Appendix E) and to the satisfaction of the Parks Forester.

If any new tree pits have to be cut, a permit must first be obtained from DOT. A permit shall be required for each block where the pavement is broken for a new pit. It is the responsibility of the applicant to notify all owners/operators of underground facilities (code 753). Owners/operators of underground facilities include but are not limited to Keyspan, Con Edison and telephone authorities. Code 753 notifications are to be made to the NYC/LI One Call Center, Briarwood Plaza, Suite 202, 36-35 Bell Boulevard, Bayside, NY 11361. Telephone No. 1-800-272-4480. A code 753 number must be obtained before any work can begin.

No pits shall be dug until proposed locations have been marked on the ground with a white 'P' by a Parks Forester. Once work begins, the applicant takes full responsibility for the tree pit locations. All excavated materials shall be removed from the site and disposed of properly. The area is to be made safe and secure at the end of the workday.

Site characteristics, such as overhead power lines, existing vegetation, and infrastructure items, such as curbs and sidewalks, shall be considered. Trees that grow taller than 25 feet should not be planted directly under power lines. When possible the tree leader shall be offset from power lines.

Where subsurface obstructions (vaults, utilities, sprinklers) are encountered during excavation and restrict the planting of a tree, the applicant shall restore the disturbed area to its original condition. If damage is done to an underground obstruction, it is the responsibility of the applicant to restore the site to its original condition. A new planting location will be designated if conditions permit.

Trees shall be transported and handled with utmost care to ensure adequate protection against injury and desiccation. When transported in closed vehicles, plants shall receive adequate ventilation to prevent sweating. When transported in open vehicles, plants shall be protected by tarpaulins or other suitable cover material. Balled and burlapped trees shall be set on the ground and balls covered with soil. Until planted, all materials shall be properly maintained and kept adequately watered. Applicants are liable for any damage to property caused by planting operations and related work. All disturbed areas shall be restored to their original condition.

Applicants are only permitted to occupy an 8 foot lane adjacent to the curb. Traffic shall not be blocked off at any time during planting operations. Work shall not be performed on opposite sides of the street at the same time. Existing parking regulations shall be complied within so far as "No Standing" rules apply for the time limits specified.

Planting Seasons

Trees may be planted in the fall from October 1 through December 15, and in the spring from March 1 through May 15. No planting is permitted in the summer. Please be aware of the DOT Construction Embargo from November 21 through January 2 and any other restrictions (streets may vary from year to year, please check DOT's website).

Installation

Remove all materials from the tree pit for the full length and width of the tree pit to the depth of the tree's root ball (Appendix E). For excavation of a lawn strip, excavate an area at least three times the diameter of the root ball in length by the width of the lawn strip (up to 3 times the diameter of the root ball), to the dimensions listed on the permit. Extreme care shall be taken to avoid excavation to a depth greater than required. The subgrade below the root ball shall be tamped slightly to prevent settlement. All ropes, stones, etc. shall be removed from the planting site before backfilling. All excavated materials shall be removed from the site and disposed of in an acceptable manner.

Place balled and burlapped material in the prepared planting pit by lifting and carrying it by the root ball so that the ball will not be loosened. Set the tree straight and in the center of the pit. All trees shall sit, after settlement, with the base of the trunk and the beginning of the roots, known

as the “trunk flare”, level with the sidewalk grade. If the top of the root ball is not consistent with this area, the depth of the planting site should be adjusted by adding or removing soil below the root ball to make the trunk flare level with the sidewalk grade.

Cut and remove rope and wire from the top 2/3 of the root ball. At least 2/3 of the burlap shall be removed from the tree pit. The remaining wires should be pulled back and the burlap adjusted to prevent the formation of air pockets. Backfilling mixture shall be loose and friable and not frozen. Soil shall be firmed at 6 to 8 inch intervals. All tree pits are to be filled with topsoil and made level with existing conditions.

Cultivate and rake over finished planting areas leaving them in an orderly condition. At no time should topsoil be mounded to cover the trunk of the tree. The trunk flare shall always be visible. Final soil level shall be flush with the surrounding sidewalk grade to prevent potential tripping hazard.

Tree Wrap

No tree trunks shall be wrapped. Remove all nursery tags and protective wrapping.

Staking

All staking shall be done during the planting operation and shall be maintained throughout the first year of the 2 year guarantee period. After the first year, the stakes must be removed.

Stakes shall be of white cedar with bark attached and shall show no sign of cracking or decay. They shall have a maximum allowable deflection of ten percent (10%). Stakes shall be cut even so they are the same height. All trees shall be supported by 2 stakes, they shall be 8 feet long; the diameter at the middle shall be not less than 2 inches nor more than 2 ¾ inches and the diameter at the butt shall not exceed 3 inches. Stakes shall be placed outside of the rootball, driven 30 inches into the ground, and shall be fastened to the tree with a suitable length of ¾” wide, flat, woven polypropylene material such as Arbortie™ as manufactured by DeepRoot®, San Francisco, CA or approved equal that is knotted around the tree stakes (Appendix E).

Unless otherwise directed, trees shall be staked as shown on the plans and in accordance with these specifications. Stakes shall be set parallel to curbs. Trees shall stand plumb after staking. Stakes and Arbortie™ shall be removed at the end of the first year of the 2 year guarantee period, unless directed otherwise by the Forester. At the time the stakes are removed any holes left by the stake shall be filled with topsoil of the same quality as that specified in Section B-Backfill.

Pruning

Pruning shall be done in accordance with ANSI A300 Part 1 Standard Practices for structural pruning. When directed by the Forester, trees shall be pruned so the resulting crown retains the growth habit of the tree species. Any and all branches interfering with or hindering the healthy growth of the tree shall be removed. All diseased branches and all dead branches shall be removed. Any branch which may be partly dead, yet has a healthy lateral branch at least one-third the diameter of the parent branch shall be removed beyond the healthy branch. All stubs or improper cuts resulting from former pruning shall be removed. All cuts shall be cleanly made with sharp tools as close to the parent trunk or limb as possible without disturbing the branch

bark ridge or callus collar. Any existing nails, spikes, wire, plastic or other materials found driven into or fastened to the trunk or branches shall be removed or if approved they shall be cut flush in a manner to permit complete healing over.

Watering

At the time of planting, the soil around each tree shall be thoroughly saturated with at least 20 gallons (20 gal) of water. Soil shall be firmed at 6-8 inch intervals and thoroughly settled with water. Water shall be free from oil, have a pH not less than 6.0 nor greater than 8.0 and shall be free from impurities injurious to vegetation. Water may be drawn from mains owned by or supplying water to the City of New York. Please contact DEP for an access permit.

Water shall not be applied in a manner which damages plants, stakes, or adjacent areas. Each tree bed shall be watered evenly in a manner which does not erode the soil or mulch. Watering shall not cause uprooting or exposure of plant roots to the air.

Mulching

Bark Mulch shall be applied as a ground cover to the surface of all planting beds at the time of planting and again after the tree stakes have been removed, one year after planting. (See p.9 for Mulch specifications).

Mulch shall be applied to a uniform depth of 3 inches and shall be so distributed as to create a smooth, level cover over the exposed soil. A gap of approximately 2 inches should be left between the mulch and the trunk of the tree to avoid mounding above the trunk flare.

Seasonal Maintenance

Watering

Watering must take place throughout the 2 year guarantee period, at least 20 gallons at approximately two week intervals from May 15 to October 31. You may need to increase or reduce the frequency of watering based on weather conditions, resulting soil water content or other factors.

Water shall not be applied in a manner which damages plants, stakes, or adjacent areas. Each tree bed shall be watered evenly in a manner which does not erode soil or mulch. Watering shall not cause uprooting or exposure of plant's roots to the air.

Damages resulting from these operations shall be immediately repaired at the expense of the applicant.

Other Maintenance Activities

All newly planted trees shall be maintained by the tree work entity and/or applicant until 2 years after the final inspection of permitted planting (sign-off date).

Maintenance shall include weeding, cultivating, edging, pruning, adjustment and timely removal of stakes, and Arbortie™ (these must be removed after one year), repair of minor washouts,

mulching, soil replacement and other horticultural operations necessary for the proper growth of all trees, and for keeping the entire area within the planting area neat in appearance.

All planting areas shall be cultivated and weeded with hoes or other approved tools within the period from May 15 to October 31, and such cultivating and weeding shall be repeated at least every 3 weeks. Under no conditions shall weeds be allowed to attain more than 6 inches of growth.

Pit pavement shall be maintained flush with adjacent pavement during the 2 year guarantee period. At the expiration of the guarantee period, the area around the tree shall be cultivated and weed free.

Guarantee Period

All trees must be guaranteed for 2 years. All applicants and tree work entities listed on a permit shall provide a guarantee for the trees planted. Applicants are advised to ensure that their tree work entity provides a guarantee otherwise they will may be held liable under the permit for replacing the tree.

Tree Replacement

Any tree planted that is dead or, in the opinion of Parks, in an unhealthy or unsightly condition, and/or has lost its natural shape due to dead branches, excessive pruning, inadequate or improper maintenance, or other causes including vandalism, prior to final acceptance, shall be replaced in the next planting season. There shall be a 2 year guarantee on trees commencing after the final inspection of the permitted planting (sign-off date). The topsoil in the tree pit shall be changed when any replacement tree is planted.

Where dead trees have been identified, whether due to natural causes or vandalism, the dead material shall be removed, including stakes, and Arbortie™ within 30 days of notification. When necessary, topsoil, grass seed or appropriate paving material shall be added to the pit to eliminate potential tripping hazards at the time of removal. Photos must be submitted to Parks showing the proper removal of trees. A renewed permit must be obtained to replant during the planting season.

Vandalism

Where vandalism or related causes are agreed as the cause for tree replacement, the applicant shall be responsible for all necessary replacements during the 2 year guarantee period as determined by the Forester.

Finishing

Tree Pit Guards

Tree pit guards may be required by Parks. A tree pit guard is usually a cast-iron fence or wrought iron wickets, installed around a tree pit for protection. Parks recommends a low cast-iron fence or wrought-iron wickets that is 18 inches high. Tree guard posts shall be solid steel or reinforced aluminum. Tree guards must be three sided leaving the street side open and should

not be embedded into concrete. This will protect the tree from dogs and pedestrians and give it enough space to grow for many years to come.

NYC Parks has standardized and approved designs which are encouraged for all tree guard installations (Appendix D). Alternative designs may be approved on a case-by-case basis and must be three-sided, approximately 18 inches tall, with no sharp points, installed on the outer perimeter of the tree bed, and positioned at least one foot short of the curb with the curbside open. Solid walls are not permissible. Water must be able to flow into the tree bed on all sides. The applicant takes full responsibility for maintaining the tree guard in a safe condition. If the condition of the tree guard is not maintained in a safe condition the tree guard will be removed by NYC Parks. Interested parties should apply for a permit to 'Install Tree Guard' before installing a tree guard. The permit is to 'Install Tree Guard'.

Tree Grates

Sidewalk-level tree grates are not permitted.

Pavers

Pavers are also not to be used without express written permission from Parks.

Other

Never plant Ivy or woody shrubs/plants in the tree pit as they compete with the tree for vital nutrients.

APPENDICES

Appendix A

LIST OF APPROVED SPECIES

- | | | | |
|----|--|----|--|
| 1 | <i>Abies concolor</i> | 44 | <i>Betula nigra</i> 'Heritage' |
| 2 | <i>Acer buergerianum</i> | 45 | <i>Betula nigra</i> 'Duraheat' |
| 3 | <i>Acer campestre</i> | 46 | <i>Carpinus betulus</i> |
| 4 | <i>Acer campestre</i> 'Evelyn' | 47 | <i>Carpinus betulus</i> 'Emerald Avenue' |
| 5 | <i>Acer campestre</i> 'Metro Gold' | 48 | <i>Carpinus betulus</i> 'Fastigiata' |
| 6 | <i>Acer campestre</i> 'Queen Elizabeth' | 49 | <i>Carpinus caroliniana</i> |
| 7 | <i>Acer ginnala</i> | 50 | <i>Carpinus caroliniana</i> 'Native Flame' |
| 8 | <i>Acer ginnala</i> 'Flame' | 51 | <i>Carpinus japonica</i> |
| 9 | <i>Acer ginnala</i> 'Ruby Slippers' | 52 | <i>Catalpa ovata</i> |
| 10 | <i>Acer griseum</i> | 53 | <i>Catalpa speciosa</i> |
| 11 | <i>Acer palmatum</i> | 54 | <i>Celtis laevigata</i> |
| 12 | <i>Acer pennsylvanicum</i> | 55 | <i>Celtis occidentalis</i> |
| 13 | <i>Acer pseudoplatanus</i> 'Atropurpureum' | 56 | <i>Celtis occidentalis</i> 'Magnifica' |
| 14 | <i>Acer maximowiczianum</i> | 57 | <i>Celtis occidentalis</i> 'Chicagoland' |
| 15 | <i>Acer miyabe</i> 'State Street' | 58 | <i>Celtis occidentalis</i> 'Praire Sentinal' |
| 16 | <i>Acer x freemanii</i> 'Armstrong' | 59 | <i>Cercidiphyllum japonicum</i> |
| 17 | <i>Acer x freemanii</i> 'Autumn Blaze' | 60 | <i>Cercis canadensis</i> |
| 18 | <i>Acer rubrum</i> 'Bowhall' | 61 | <i>Cercis canadensis</i> 'Crosswicks Red' |
| 19 | <i>Acer rubrum</i> 'Frank Jr.' | 62 | <i>Cercis canadensis</i> 'Appalachain Red' |
| 20 | <i>Acer rubrum</i> 'Franksred' | 63 | <i>Cercis canadensis</i> 'Forest Pansy' |
| 21 | <i>Acer rubrum</i> 'Karpick' | 64 | <i>Cercis canadensis</i> 'Hearts of Gold' |
| 22 | <i>Acer rubrum</i> 'October Glory' | 65 | <i>Cercis canadensis</i> 'Royal White' |
| 23 | <i>Acer rubrum</i> 'Red Sunset' | 66 | <i>Cercis canadensis</i> var. Alba |
| 24 | <i>Acer rubrum</i> 'Redpointe' | 67 | <i>Cercis chinensis</i> 'Avondale' |
| 25 | <i>Acer x freemanii</i> 'Scarsen' | 68 | <i>Cercis reniformis</i> 'Oklahoma' |
| 26 | <i>Acer saccharinum</i> | 69 | <i>Chamaecyparis obtusa</i> 'Crippsii' |
| 27 | <i>Acer tataricum</i> 'Rugged Charm' | 70 | <i>Chionanthus retusus</i> |
| 28 | <i>Acer tataricum</i> 'Pacific Sunset' | 71 | <i>Chionanthus virginicus</i> |
| 29 | <i>Acer tataricum</i> 'Pattern Perfect' | 72 | <i>Cladrastis kentukea</i> |
| 30 | <i>Acer tataricum</i> 'Hot Wings' | 73 | <i>Cladrastis kentukea</i> 'Sweetshade' |
| 31 | <i>Acer truncatum</i> 'Norwegian Sunset' | 74 | <i>Cladrastis kentukea</i> 'Perkins Pink' |
| 32 | <i>Aesculus</i> 'Autumn Splendor' | 75 | <i>Cornus</i> 'June Snow' |
| 33 | <i>Aesculus glabra</i> | 76 | <i>Cornus</i> 'Venus' |
| 34 | <i>Aesculus hippocastanum</i> 'Baumanni' | 77 | <i>Cornus</i> 'Constellation' |
| 35 | <i>Aesculus octandra</i> | 78 | <i>Cornus florida</i> 'Cherokee Sunset' |
| 36 | <i>Aesculus x carnea</i> 'Briotii' | 79 | <i>Cornus florida</i> 'Cherokee Brave' |
| 37 | <i>Aesculus x carnea</i> 'Fort McNair' | 80 | <i>Cornus florida</i> 'Cherokee Princess' |
| 38 | <i>Amelanchier canadensis</i> 'Robin Hill' | 81 | <i>Cornus kousa</i> 'Summer Stars' |
| 39 | <i>Amelanchier laevis</i> | 82 | <i>Cornus mas</i> |
| 40 | <i>Amelanchier laevis</i> 'Spring Flurry' | 83 | <i>Cornus mas</i> 'Spring Sun' |
| 41 | <i>Amelanchier lamarkii</i> | 84 | <i>Corylus colurna</i> |
| 42 | <i>Amelanchier x grandiflora</i> 'Autumn Brilliance' | 85 | <i>Cotinus coggygria</i> |
| 43 | <i>Amelanchier x grandiflora</i> 'Princess Diana' | 86 | <i>Cotinus</i> 'Grace' |
| | | 87 | <i>Crataegus</i> 'Crimson Cloud' |
| | | 88 | <i>Crataegus crusgalli</i> var. inermis |

- 89 *Crataegus* 'Lavellus'
90 *Crataegus phaenopyrum* 'Washington'
91 *Crataegus viridis* 'Winter King'
92 *Cryptomeria japonica* 'Angelica'
93 *Cryptomeria japonica* 'Black Dragon'
94 *Cryptomeria japonica* 'Yoshino'
95 *Eucommia ulmoides*
96 *Eucommia ulmoides* 'Emerald Pointe'
97 *Eucommia ulmoides* 'Emerald
Sunshine'
98 *Fagus sylvatica* 'Dawyckii Purple'
99 *Fagus sylvatica* 'Riversii'
100 *Fraxinus americana*
101 *Fraxinus pennsylvanica* 'Leprechaun'
102 *Fraxinus pennsylvanica* 'Patmore'
103 *Ginkgo biloba*
104 *Ginkgo biloba* 'Autumn Gold'
105 *Ginkgo biloba* 'Columnaris'
106 *Ginkgo biloba* 'Fairmont'
107 *Ginkgo biloba* 'Fastigiata'
108 *Ginkgo biloba* 'Magyar'
109 *Ginkgo biloba* 'Princeton Sentry'
110 *Ginkgo biloba* 'Shangri-la'
111 *Gleditsia triacanthos* var. *inermis*
'Draves'
112 *Gleditsia triacanthos* var. *inermis*
'Halka'
113 *Gleditsia triacanthos* var. *inermis*
'Shademaster'
114 *Gleditsia triacanthos* var. *inermis*
'Imperial'
115 *Gleditsia triacanthos* var. *inermis*
'Skyline'
116 *Gleditsia triacanthos* var. *inermis*
'Streetkeeper'
117 *Gymnocladus dioicus*
118 *Gymnocladus dioicus* 'Espresso'
119 *Gymnocladus dioicus* 'Prairie Titan'
120 *Halesia carolina*
121 *Halesia carolina* 'Arnold Pink'
122 *Halesia diptera* 'Magniflora'
123 *Halesia* 'Jersey Belle'
124 *Halesia monticola*
125 *Juniperus chinensis* 'Hetzii'
126 *Juniperus chinensis* 'Ketleri'
127 *Juniperus virginiana*
128 *Koelreuteria paniculata*
129 *Koelreuteria paniculata* 'Fastigiata'
130 *Koelreuteria paniculata* 'Gold Candle'
131 *Koelreuteria paniculata* 'Rose Lanterns'
132 *Laburnum x watereri*
133 *Lagerstroemia* 'Muskogee'
134 *Lagerstroemia* 'Natchez'
135 *Lagerstroemia* 'Tuskogee'
136 *Liquidambar formosana*
137 *Liquidambar styraciflua*
138 *Liquidambar styraciflua* 'Cherokee'
139 *Liquidambar styraciflua* 'Happidaze'
140 *Liquidambar styraciflua* 'Moraine'
141 *Liquidambar styraciflua* 'Slender
Sliouette'
142 *Liquidambar styraciflua* 'Worplesdon'
143 *Liriodendron tulipifera* 'Arnold'
144 *Liriodendron tulipifera* 'Emerald City'
145 *Maackia amurensis*
146 *Maackia amurensis* 'Starburst'
147 *Magnolia* 'Butterflies'
148 *Magnolia* 'Elizabeth'
149 *Magnolia macrophylla*
150 *Magnolia soulangiana*
151 *Magnolia soulangiana* 'Rustica Rubra'
152 *Magnolia* 'Wades Memory'
153 *Malus* 'Adams'
154 *Malus* 'Cardinal'
155 *Malus* 'Centurion'
156 *Malus* 'Coralburst'
157 *Malus* 'Dolgo'
158 *Malus* 'Donald Wyman'
159 *Malus* 'Harvest Gold'
160 *Malus* 'Sugartyme'
161 *Malus* 'Prariefire'
162 *Malus* 'Pink Spire'
163 *Malus* 'Robinson'
164 *Malus* 'Spring Snow'
165 *Malus* 'Sugartyme'
166 *Metasequoia glyptostroboides*
167 *Metasequoia glyptostroboides* 'Gold
Rush'
168 *Nyssa sylvatica*
169 *Nyssa sylvatica* 'Forum'
170 *Nyssa sylvatica* 'Red Rage'
171 *Nyssa sylvatica* 'Wildfire'
172 *Ostrya virginiana*
173 *Parrotia persica*
174 *Parrotia persica* 'Vanessa'
175 *Parrotia persica* 'Ruby Vase'
176 *Pistache chinensis*
177 *Pistache chinensis* 'Pairs Choice'
178 *Platanus x acerifolia* 'Bloodgood'
179 *Platanus x acerifolia* 'Columbia'
180 *Platanus x acerifolia* 'Exclamation'
181 *Prunus* 'Amanowagawa'

- 182 *Prunus blireana*
183 *Prunus cerasifera* 'Crimson Point'
184 *Prunus cerasifera* 'Krauter Vesuvius'
185 *Prunus cerasifera* 'Mt. St. Helens'
186 *Prunus cerasifera* 'Newport'
187 *Prunus cerasifera* 'Thundercloud'
188 *Prunus cistena* 'Schmidtcs'
189 *Prunus* 'Dreamcatcher'
190 *Prunus* 'Holly Jolivette'
191 *Prunus* 'Mount St. Helens'
192 *Prunus* 'Mt Fuji'
193 *Prunus* 'Okame'
194 *Prunus padus*
195 *Prunus padus* 'Merlot'
196 *Prunus padus* 'Summer Glow'
197 *Prunus* 'Princeton Snowcloud'
198 *Prunus* 'Royal Burgundy'
199 *Prunus sargentii*
200 *Prunus sargentii* 'Columnaris'
201 *Prunus sargentii* 'Rancho'
202 *Prunus serotina*
203 *Prunus serrulata* 'Kwanzan'
204 *Prunus serrulata* 'Shirotae'
205 *Prunus* 'Snow Goose'
206 *Prunus* 'Snow Goose x copper graft'
207 *Prunus subhirtella* 'Autumnalis'
208 *Prunus virginiana* 'Canada Red'
209 *Prunus x hillieri* 'Spires'
210 *Prunus x yedoensis*
211 *Prunus x yedoensis* 'Akebono'
212 *Prunus x yedoensis* 'Cascade Snow'
213 *Quercus acutissima*
214 *Quercus alba*
215 *Quercus bicolor*
216 *Quercus coccinea*
217 *Quercus* 'Crimson Spire'
218 *Quercus dentata*
219 *Quercus ellipsodalis*
220 *Quercus frainetto*
221 *Quercus garryana*
222 *Quercus imbricaria*
223 *Quercus lyrata*
224 *Quercus macrocarpa*
225 *Quercus muehlenbergii*
226 *Quercus nuttali*
227 *Quercus palustris*
228 *Quercus palustris* 'Green Pillar'
229 *Quercus phellos*
230 *Quercus phellos* 'Hightower'
231 *Quercus prinus*
232 *Quercus* 'Regal Prince'
233 *Quercus robur*
234 *Quercus robur x bicolor* 'Kindred Spirit'
235 *Quercus robur* 'Skyrocket'
236 *Quercus robur* var. 'Fastigiata'
237 *Quercus rubra*
238 *Quercus x comptoniae*
239 *Quercus sargentii*
240 *Quercus shumardii*
241 *Quercus texana*
242 *Quercus velutina*
243 *Robinia pseudoacacia* 'Frisia'
244 *Robinia pseudoacacia* 'Purple Robe'
245 *Sequoiadendron giganteum*
246 *Stewartia pseudocamellia*
247 *Styphnolobium japonicum* 'Millstone'
248 *Styphnolobium japonicum* 'Regent'
249 *Styrax japonica*
250 *Styrax japonica* 'Emerald Pagoda'
251 *Styrax japonica* 'Snowcone'
252 *Styrax obbasia*
253 *Syringa pekinensis* 'Beijing Gold'
254 *Syringa pekinensis* 'China Snow'
255 *Syringa pekinensis* 'Summer charm'
256 *Syringa reticulata*
257 *Syringa reticulata* 'Snowcap'
258 *Syringa reticulata* 'Ivory Silk'
259 *Taxodium ascendens* 'Nutans'
260 *Taxodium distichum*
261 *Taxodium distichum* 'Shawnee Brave'
262 *Tilia americana* 'Continental Appeal'
263 *Tilia americana* 'Legend'
264 *Tilia americana* 'McSentry'
265 *Tilia americana* 'Redmond'
266 *Tilia cordata* 'Corinthian'
267 *Tilia cordata* 'Corizam'
268 *Tilia cordata* 'Glenlevyn'
269 *Tilia cordata* 'Greenspire'
270 *Tilia cordata* 'Prestige'
271 *Tilia cordata* 'Shamrock'
272 *Tilia cordata* 'Unizam'
273 *Tilia mongolica* 'Harvest Gold'
274 *Tilia tomentosa* 'Green Mountain'
275 *Tilia tomentosa* 'Satin Shadow'
276 *Tilia tomentosa* 'Sterling'
277 *Tilia tomentosa* 'Szeleste'
278 *Tilia x euchlora*
279 *Tilia x euchlora* 'Laurelhurst'
280 *Ulmus* 'Accolade'
281 *Ulmus americana* 'Princeton'
282 *Ulmus americana* 'Valley Forge'
283 *Ulmus* 'Athena'

- 284 *Ulmus* 'Emerald Sunshine'
- 285 *Ulmus* 'Frontier'
- 286 *Ulmus* 'Homestead'
- 287 *Ulmus* 'Jefferson'
- 288 *Ulmus* 'Morton Glossy'
- 289 *Ulmus* 'New Harmony'
- 290 *Ulmus* 'New Horizon'
- 291 *Ulmus parvifolia* 'Everclear'
- 292 *Ulmus parvifolia* 'Allee'
- 293 *Ulmus parvifolia* 'Bosque'
- 294 *Ulmus parvifolia* 'Dynasty'
- 295 *Ulmus* 'Patriot'
- 296 *Ulmus* 'Pioneer'
- 297 *Ulmus* 'Prospector'
- 298 *Ulmus* 'Triumph'
- 299 *Zelkova serrata* 'City Sprite'
- 300 *Zelkova serrata* 'Green Vase'
- 301 *Zelkova serrata* 'Halka'
- 302 *Zelkova serrata* 'Mushashino'
- 303 *Zelkova serrata* 'Variegata'
- 304 *Zelkova serrata* 'Village Green'
- 305 *Zelkova serrata* 'Wireless'

Appendix B

STRUCTURAL SOIL

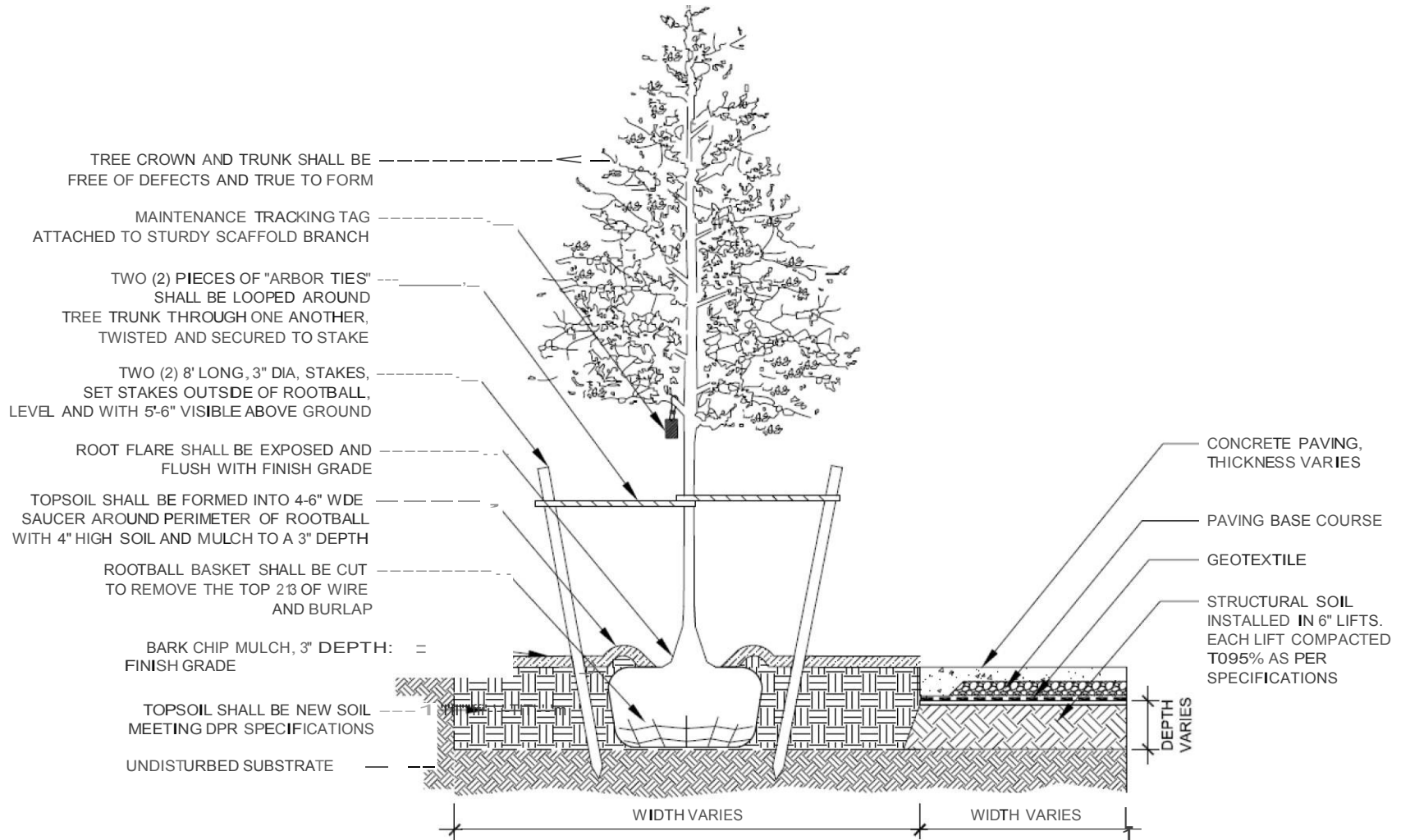

TREE PLANTING & STRUCTURAL SOIL DETAIL

NOT TO SCALE

CONTINUOUS STRUCTURAL SOIL

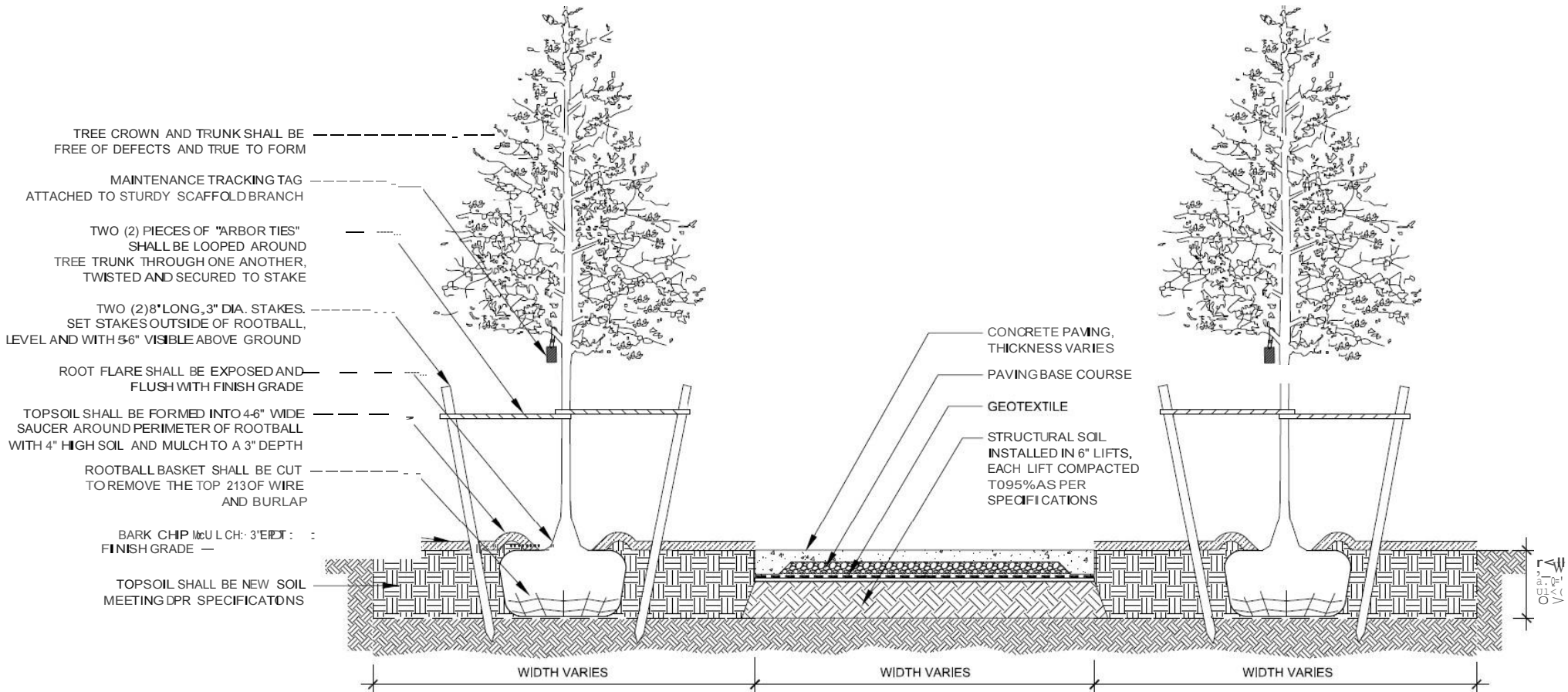

TREE PLANTING & CONTINUOUS STRUCTURAL SOIL DETAIL

NOT TO SCALE

SWEDISH STRUCTURAL SOIL

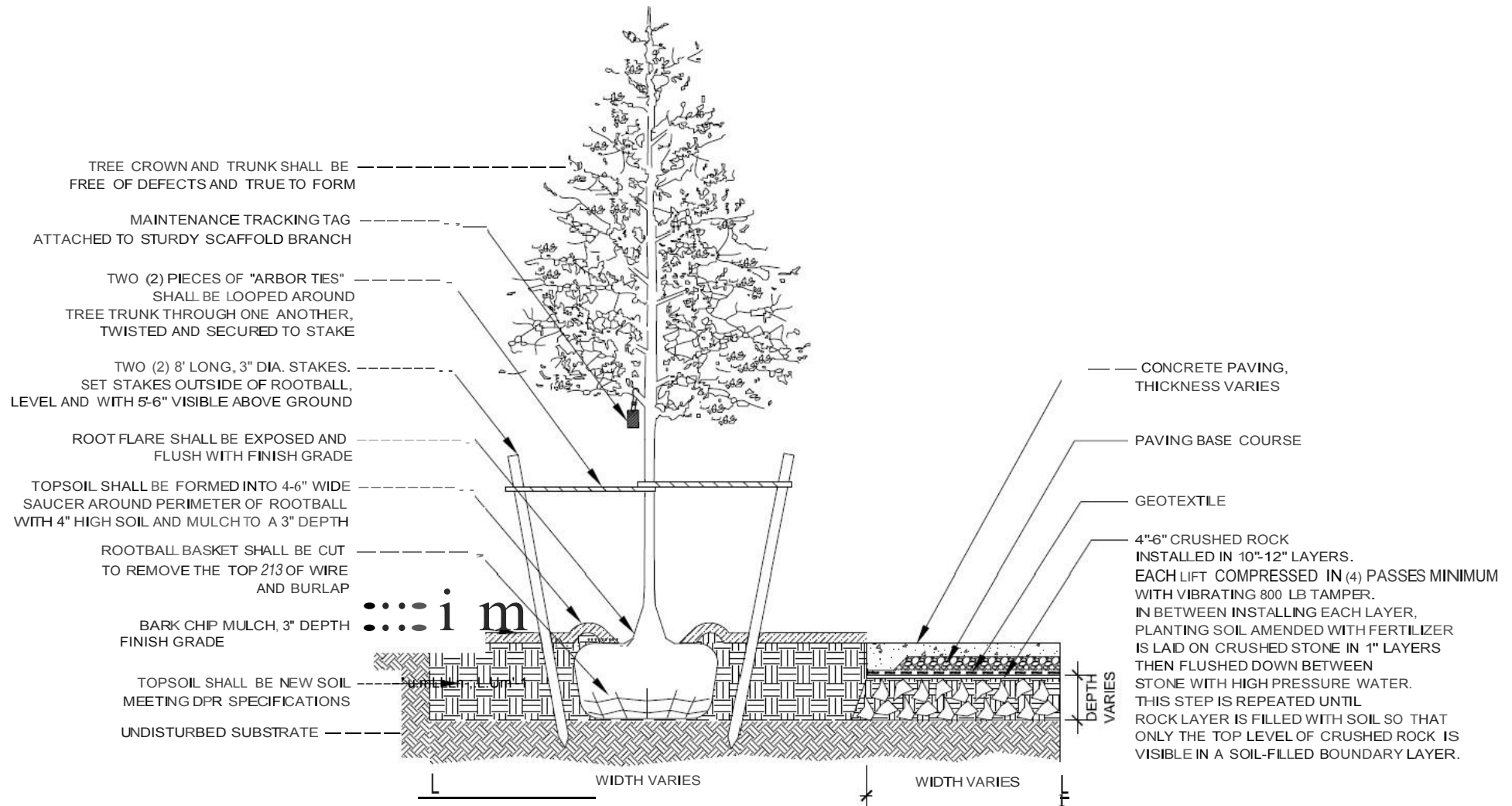

TREE PLANTING & SWEDISH STRUCTURAL SOIL DETAIL

NOT TO SCALE

Appendix C

SOIL CELL UNIT IN SINGLE LAYER

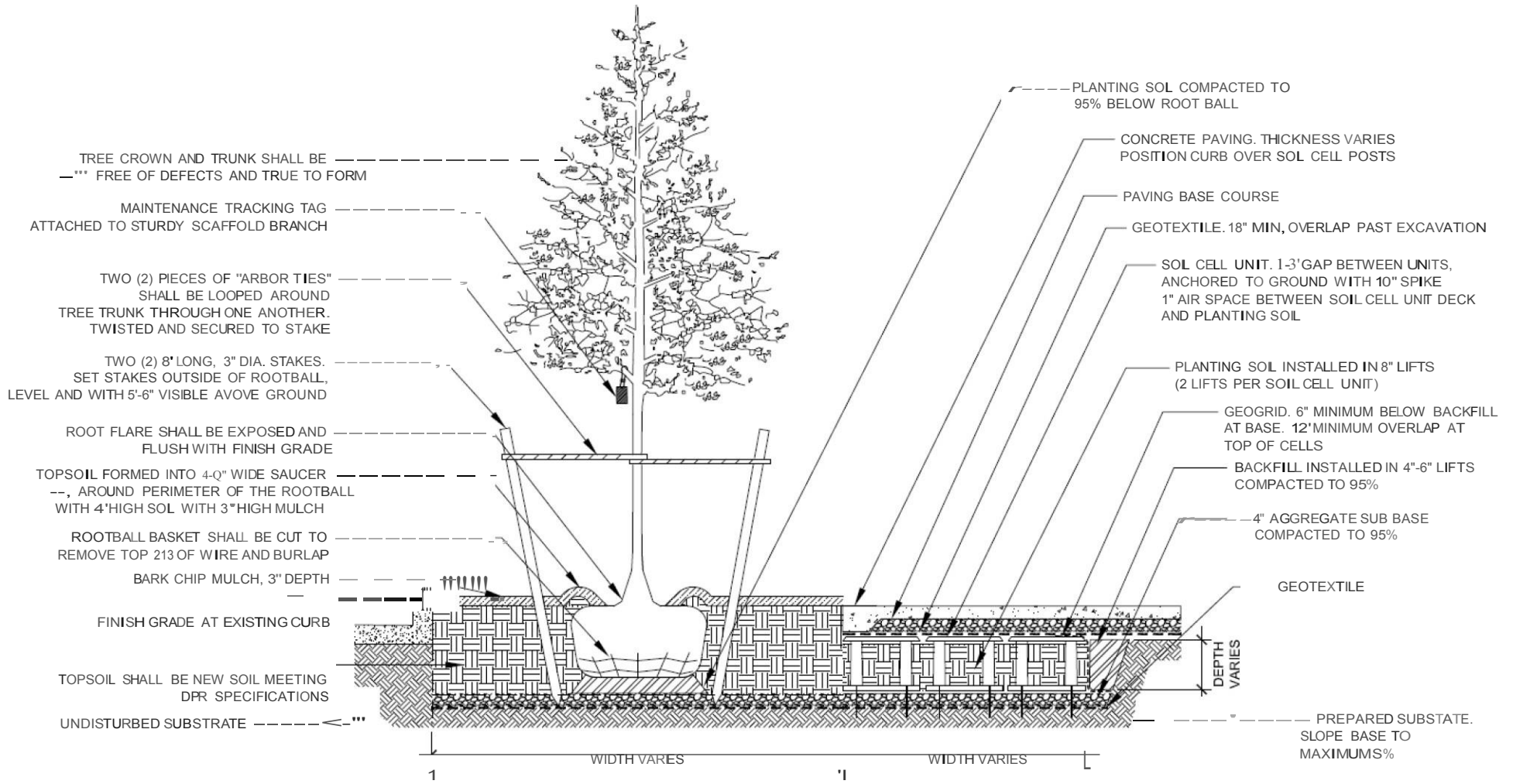

TREE PLANTING & SOIL CELL UNIT IN SINGLE LAYER DETAIL

NOT TO SCALE

SOIL CELL UNIT IN DOUBLE LAYER

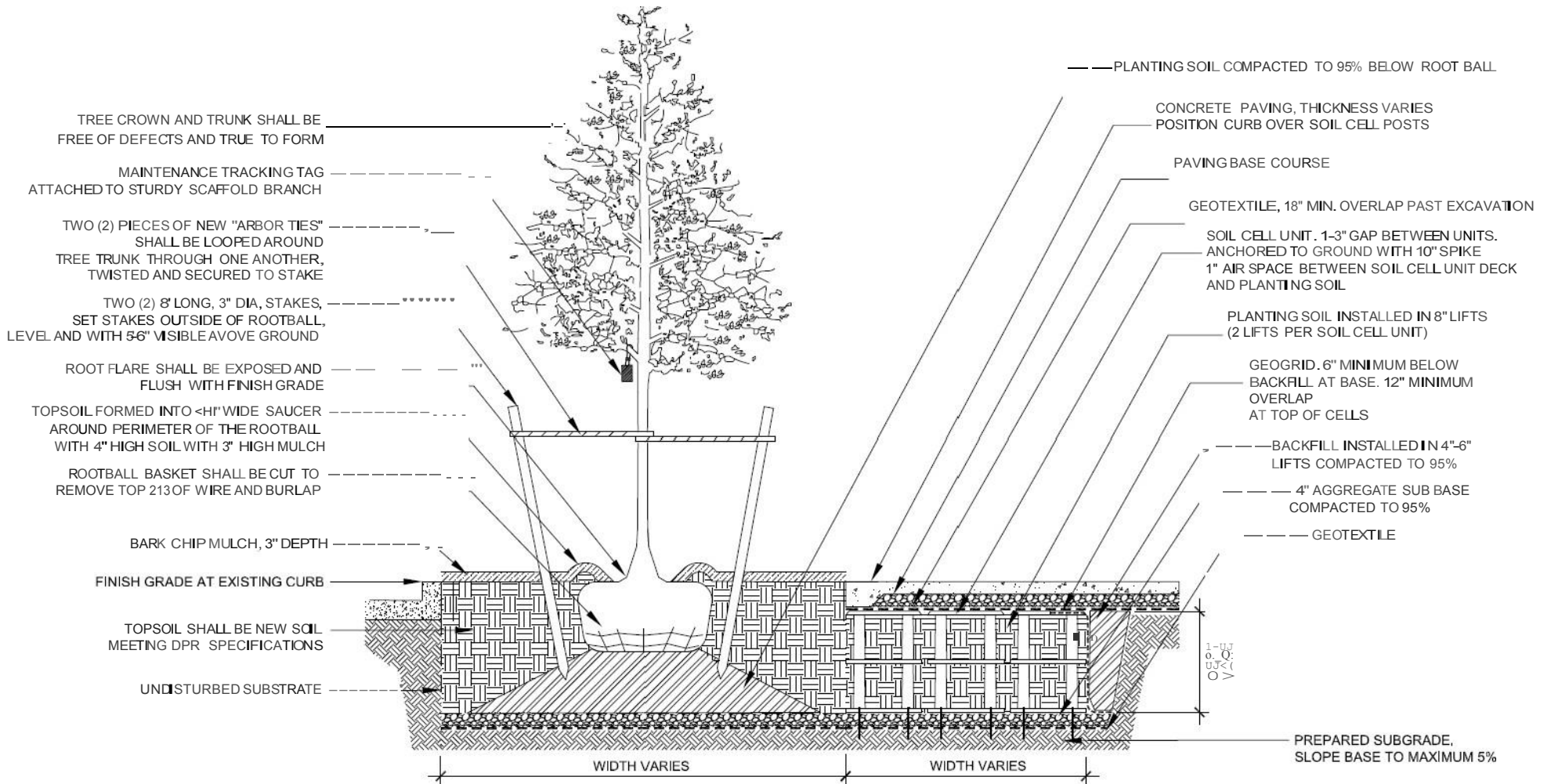

TREE PLANTING & SOIL CELL UNIT IN DOUBLE LAYER DETAIL

NOT TO SCALE

Appendix D

TREE GUARDS

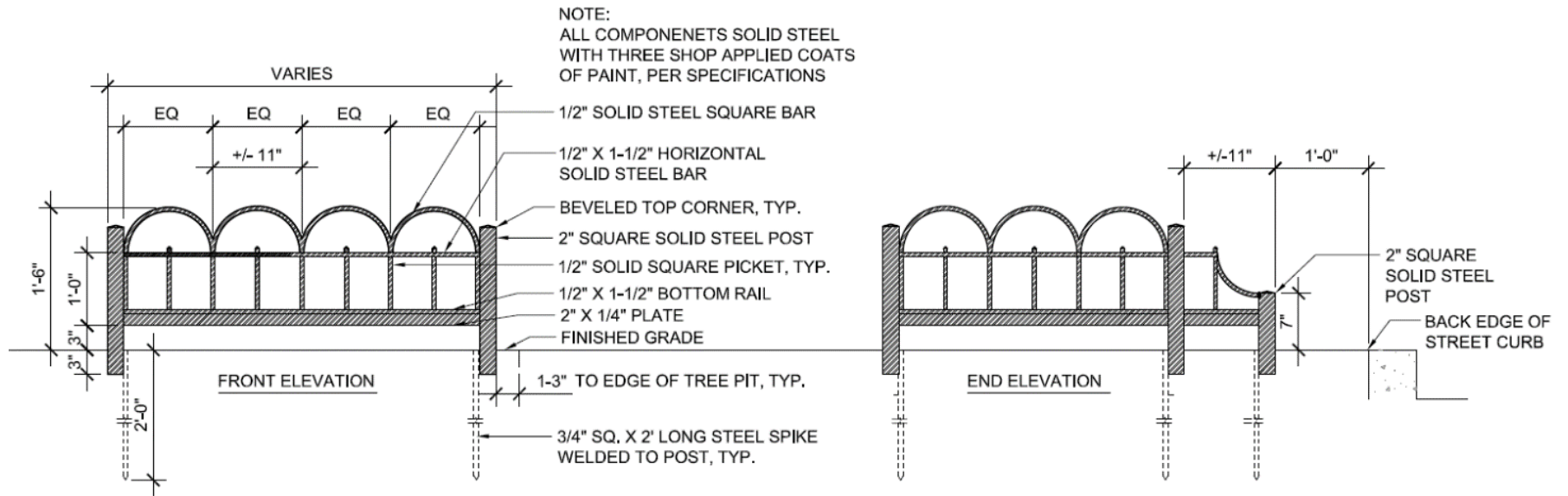

TREE PIT GUARD TYPE 'A'

NOT TO SCALE

TYPE 'A' THREE-SIDED DESIGN

NOT TO SCALE

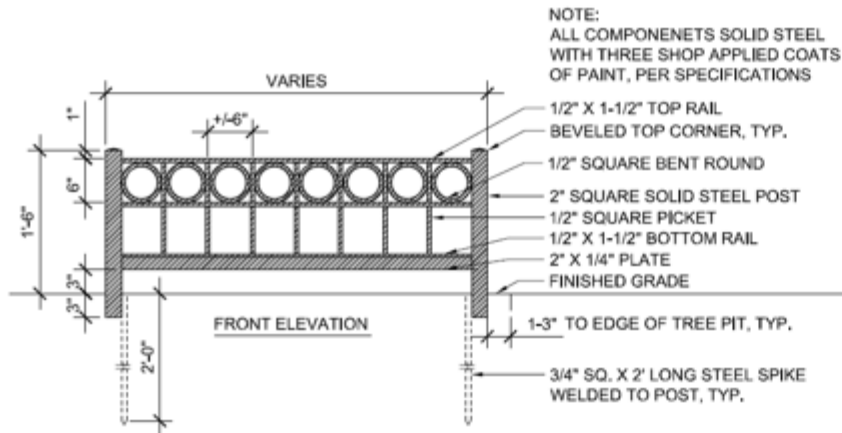

TREE PIT GUARD TYPE 'B'

NOT TO SCALE

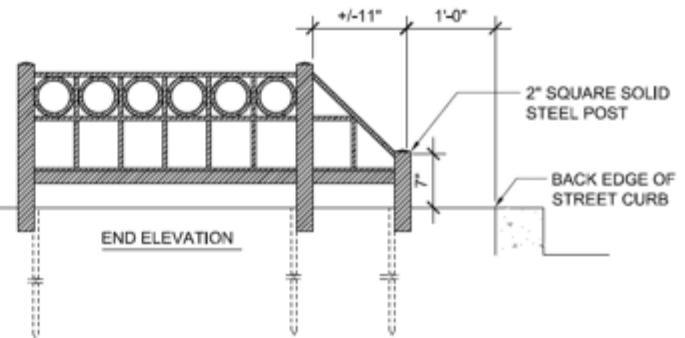

TYPE 'B' THREE-SIDED DESIGN

NOT TO SCALE

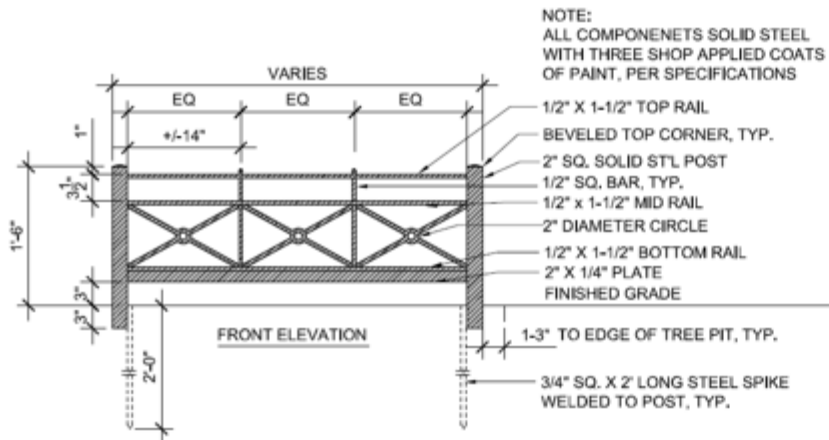

TREE PIT GUARD TYPE 'C'

NOT TO SCALE

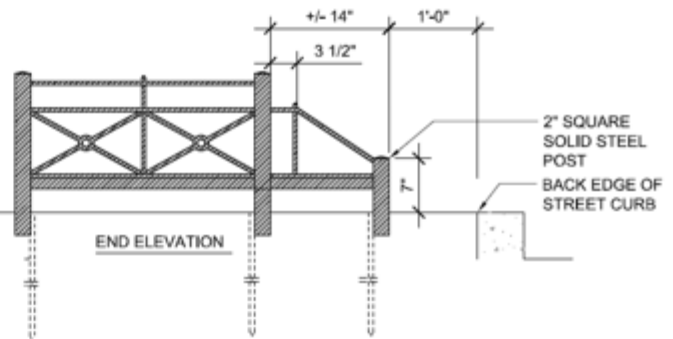

TYPE 'C' THREE-SIDED DESIGN

NOT TO SCALE

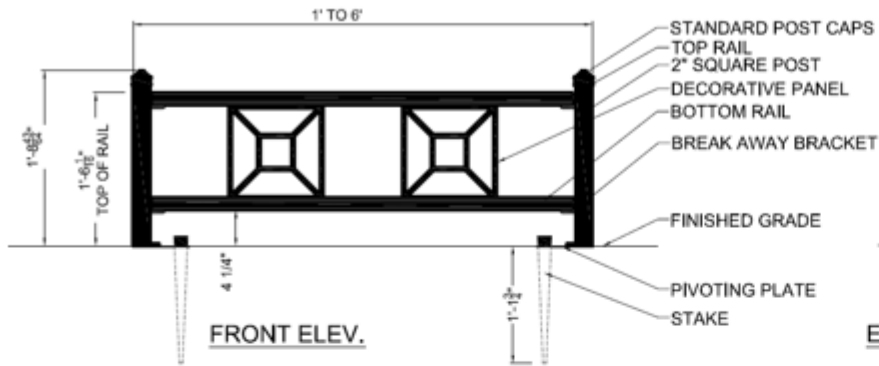

TREE PIT GUARD TYPE 'F'

SCALE: NTS

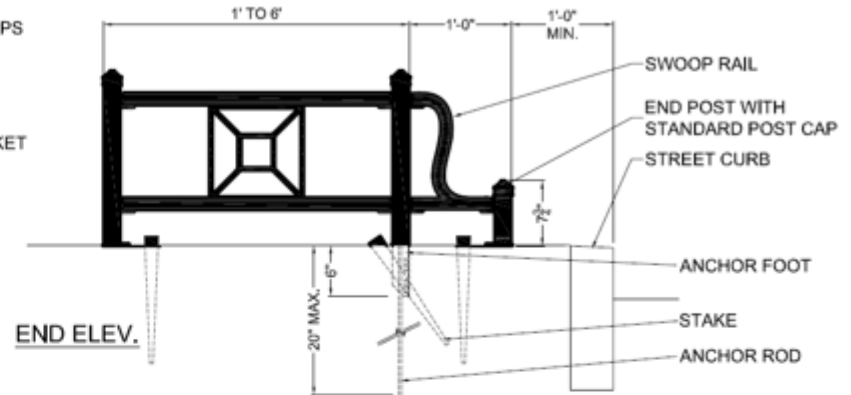

TYPE 'F' THREE SIDED DESIGN

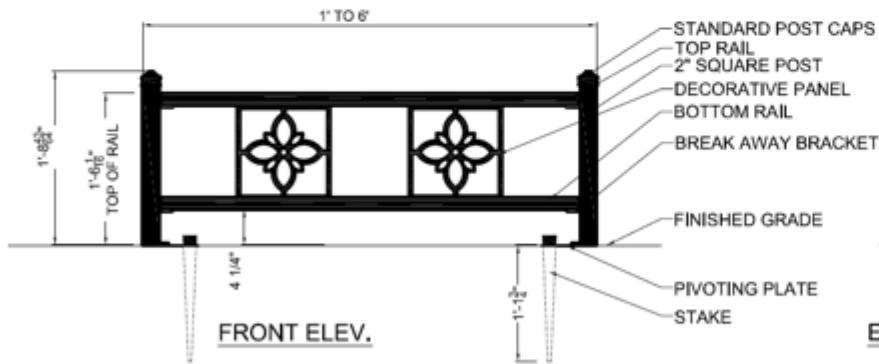

TREE PIT GUARD TYPE 'G'

SCALE: NTS

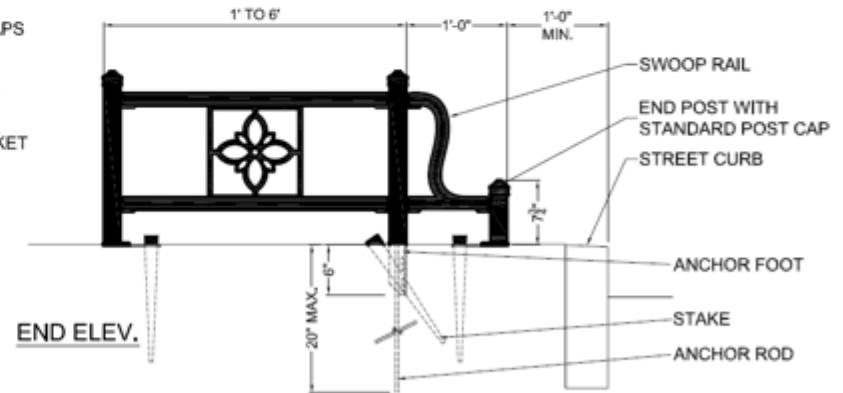

TYPE 'G' THREE SIDED DESIGN

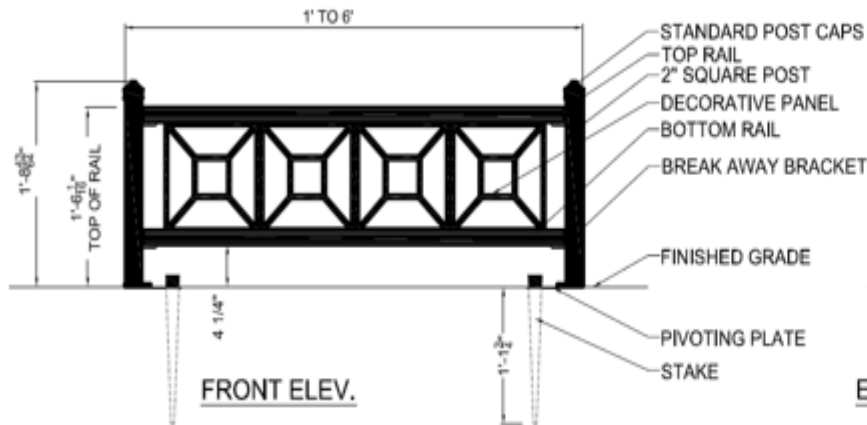

TREE PIT GUARD TYPE 'H'

SCALE: NTS

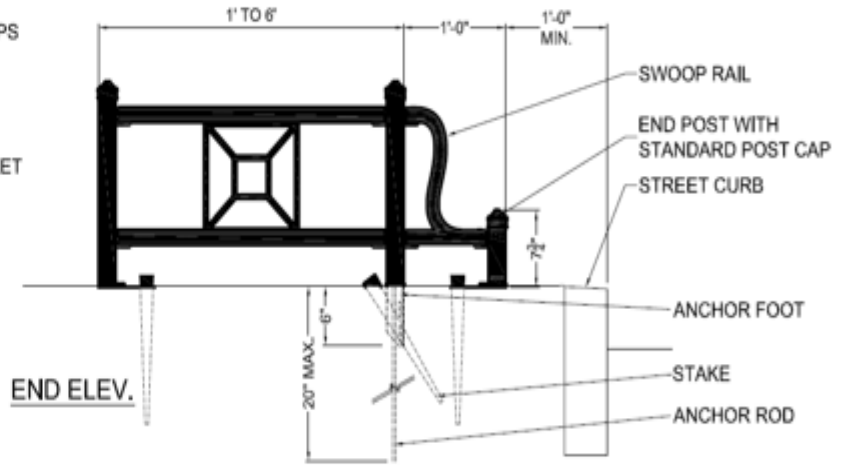

TYPE 'H' THREE SIDED DESIGN

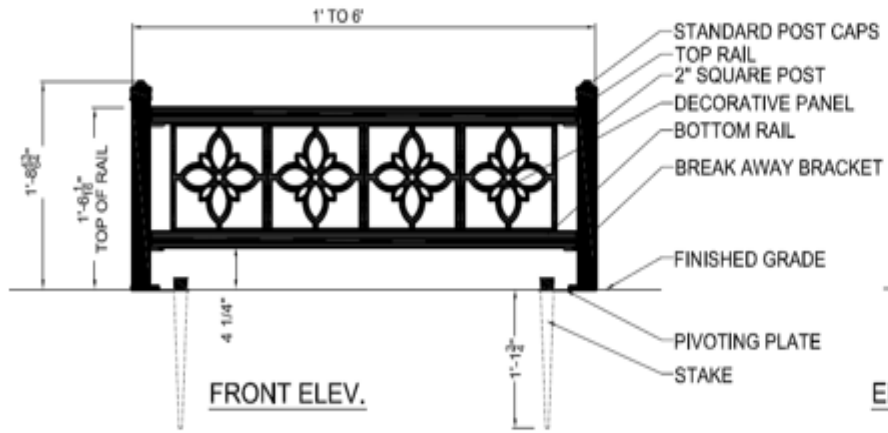

TREE PIT GUARD TYPE 'J'

SCALE: NTS

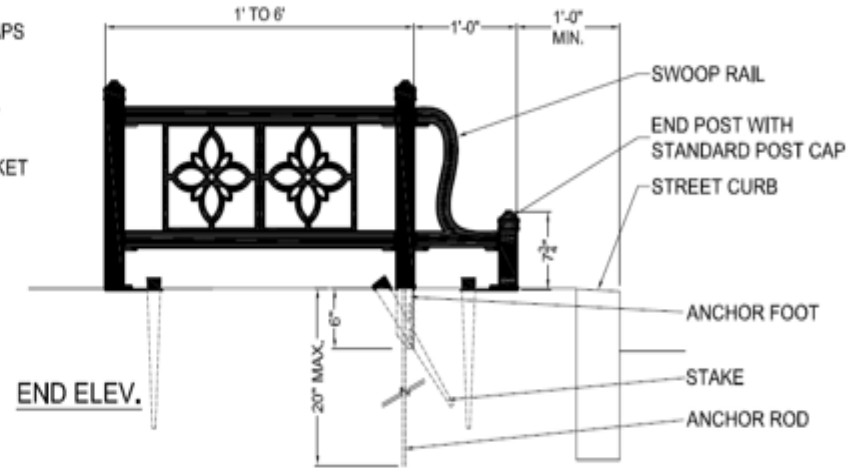

TYPE 'J' THREE SIDED DESIGN

Appendix E

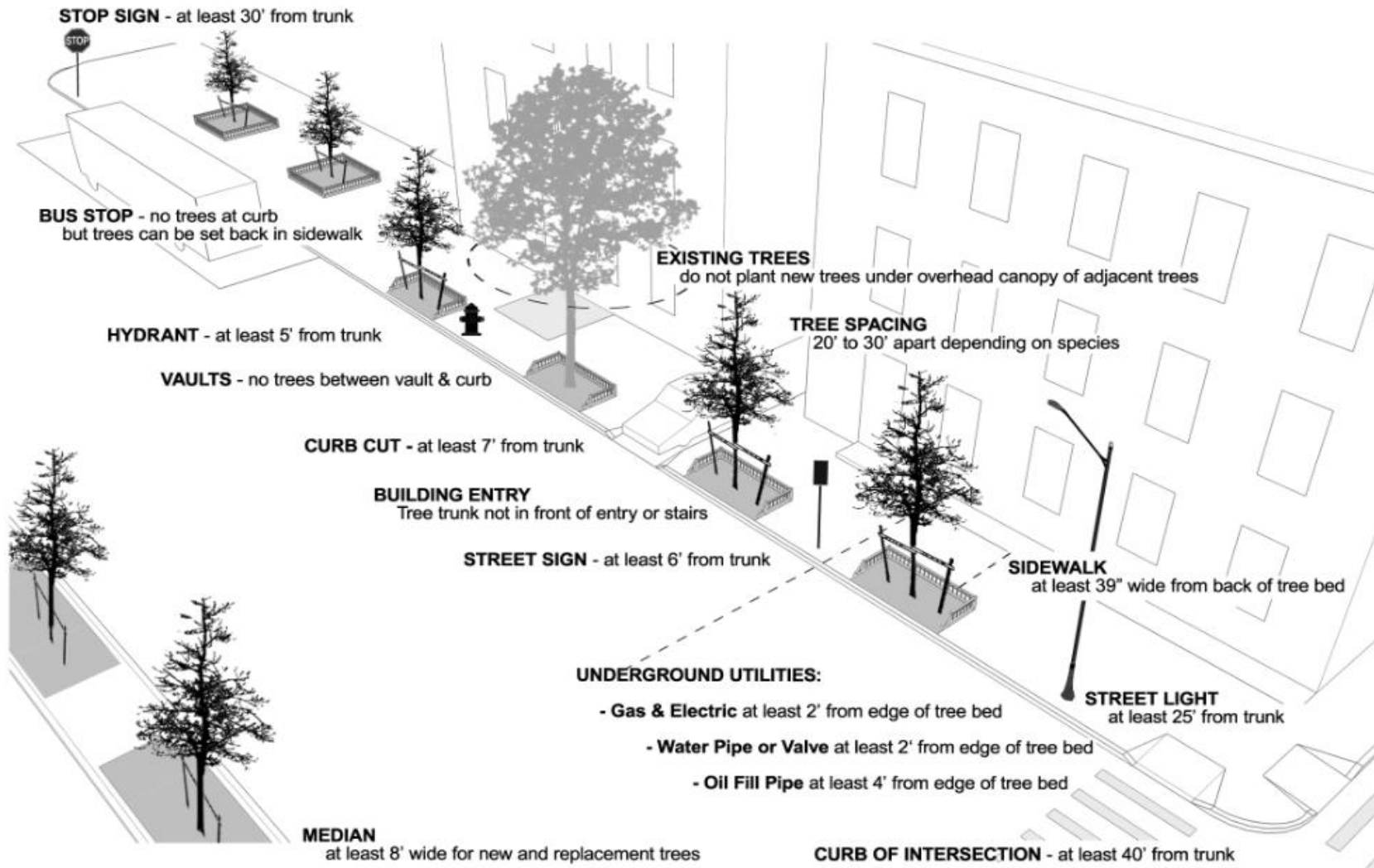

Appendix F

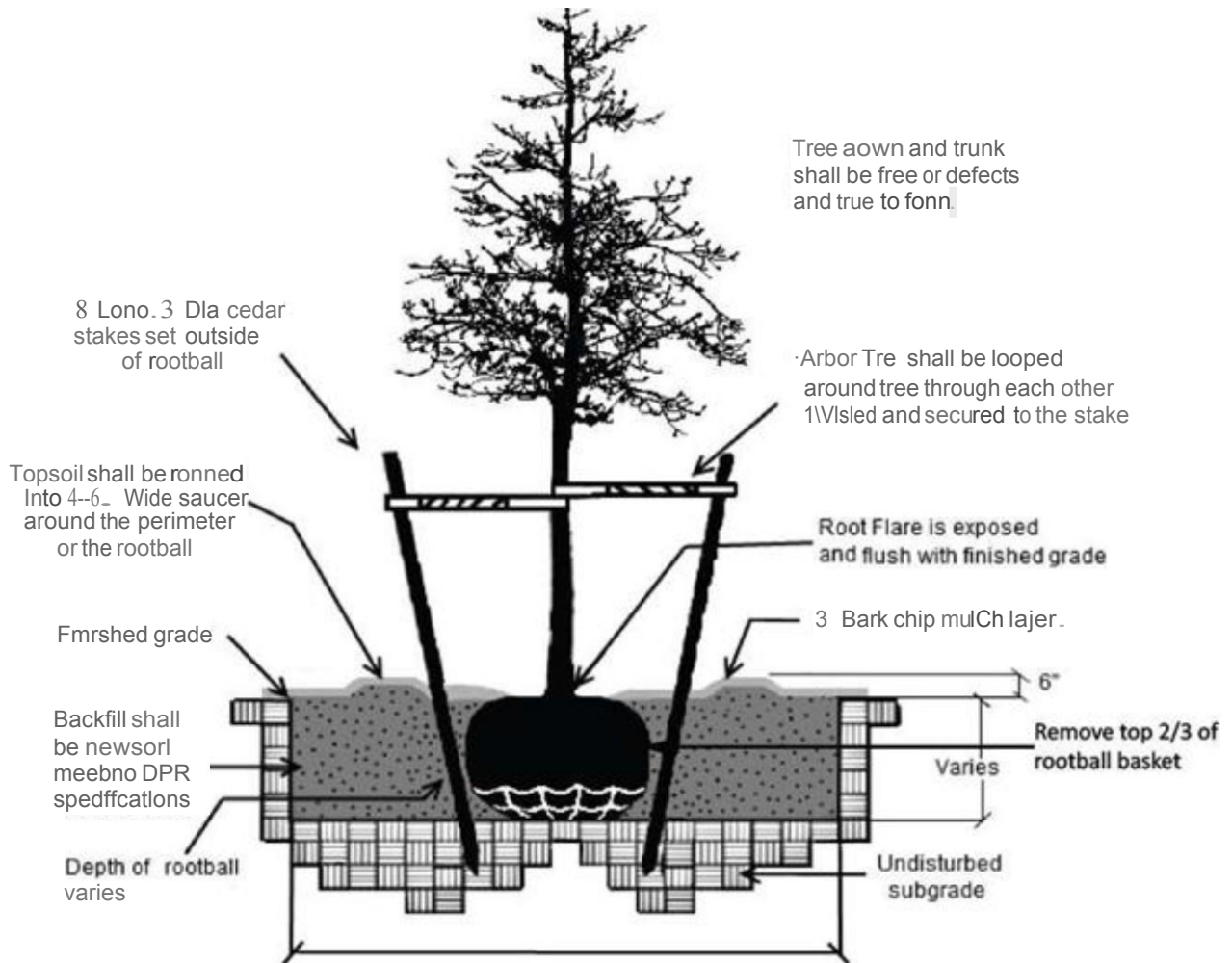

Tree Planting & Stake Detail

Not to Scale





NEW YORK CITY
SOIL AND WATER
CONSERVATION
DISTRICT



EVERGREEN



**eDESIGN
DYNAMICS**